

ISSUE	DATE	AMENDMENTS
1	08/02/17	ORIGINAL
2	28/03/17	PILOT BUILD UPDATES - WDA
3	26/05/17	1ST PRODUCTION UPDATES - WDA
4	10/04/19	COMPRESSOR AND FAN CHANGED - WDA
5	03/07/19	PCB CHANGED - WDA
6	07/10/19	EARTH ROUTING / COMPONENT LAYOUT - WDA
7	258/02/20	EARTH TAG CHANGE - WDA

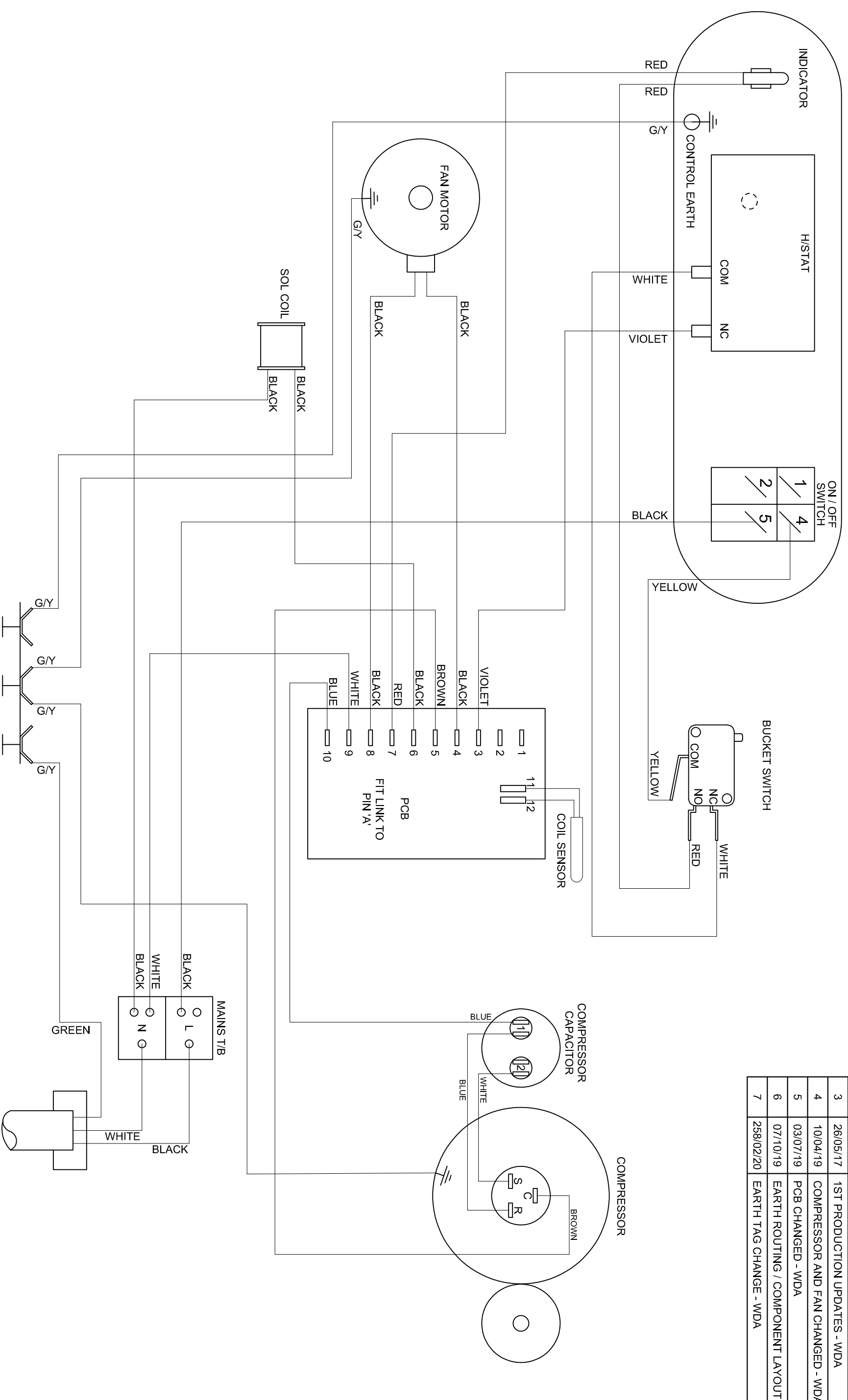

 DO NOT SCALE IF IN DOUBT ASK		 1997		BISHOP AUCKLAND Co. DURHAM ENGLAND	
DIMENSIONS IN m.m. TOLERANCES UNLESS OTHERWISE STATED O.0 ± 1 0.00 ± 0.25 ANGULAR ± 0.5 DEGREE		TITLE <b>RM40 - US 110V - DIAGRAM</b>			
MATERIAL <b>SEE DRW</b>		FINISH <b>SEE DRW</b>			
DRAWN: <b>W DAGLISH</b>		CAD SCALE: 1/1			
DRG. NO. <b>5010418</b>		SHEET 1 OF 1			