

# **EBAC LUMBER DRYER**

**OWNER'S MANUAL  
KILN CONSTRUCTION GUIDE  
TROUBLESHOOTING GUIDE**

## **MF2**

### **EBAC LUMBER DRYERS SALES & SERVICE**

**700 THIMBLE SHOALS BLVD  
SUITE 109  
NEWPORT NEWS, VA 23606-2575  
TELEPHONE: 757-873-6800  
TOLL FREE: 800-433-9011  
FAX: 757-873-3632**

**EBAC MF2  
TABLE OF CONTENTS**

Warranty -----	I
Introduction -----	II
Lumber Drying Principles -----	III
<b>KILN DESIGN &amp; CONSTRUCTION:</b>	
Stack Size Calculations -----	1
Chamber Size -----	3
Kiln Construction -----	8
MF2 Placement & Wiring -----	10
Drain lines -----	10
Wiring -----	10
Maintenance -----	11
High Temperature Vent System -----	11
<b>EBAC MODULAR CONTROL SYSTEM:</b>	
Introduction -----	13
MCU1002 Control Unit -----	13
Overview MCU1002 -----	16
24 Hour Override -----	17
Maximum Demand Reduction -----	17
Specifications MCU1002 -----	18
Installation MCU1002 -----	19
Unpacking and Pre-Installation Check -----	19
Mounting -----	19
Electrical Connections -----	19
Calibration MCU1002 -----	20
Operation MCU1002 -----	21
Maintenance MCU1002 -----	22
Spare Parts List MCU1002 -----	24
MCU1100 Control Unit -----	26
Overview MCU1100 -----	28
Installation MCU1100 -----	29
Operation MCU1100 -----	31
<b>DRYING LUMBER:</b>	
Determining Moisture Content -----	32
Drying Rate -----	33
Preparation of the Lumber Stack -----	35
Kiln Operating Instructions -----	35
Table 1 Drying Group/Schedules -----	38
Table 2 Drying Schedules By Lumber Thickness and Moisture Content -----	42
Minimum Drying Times for MF Lumber Drying -----	46
Average Load Sizes for each MF2 -----	47

**EBAC MF2  
TABLE OF CONTENTS  
(Continued)**

APPENDIXES:		
Oven Dry Method for Determining Average MC	-----	49
Wood Degrade	-----	51
Troubleshooting	-----	56
Specifications	-----	64
Drawings	-----	66



# Ebac

## LIMITED WARRANTY

---

Ebac Incorporated Lumber Dryers and Controllers carry a one year limited warranty against any defect in workmanship or material. This Warranty will cover all parts and labor required to repair your Ebac Lumber Dryer or Controller. This Warranty is invalid if the unit has been abused, damaged, whether intentional or accidental, or if any modifications have been made to the unit.

In addition, an extended warranty is provided for the evaporator coil and compressor for an additional two years (three years total). Under the extended warranty a new or remanufactured part will be supplied by Ebac, provided the defective part is first returned to Ebac for inspection. The replacement part assumes the unused portion of the warranty. The extended warranty does not include labor or other costs incurred for diagnosis, repairing or removing, installing or shipping the defective parts.

THE FOREGOING WARRANTY IS EXCLUSIVE AND IS ISSUED IN LIEU OF ALL OTHER WARRANTY OF MERCHANT ABILITY AND THE WARRANTY OF FITNESS FOR A PARTICULAR PURPOSE. EBAC INCORPORATED DISCLAIMS ANY LIABILITY FOR CONSEQUENTIAL DAMAGES, LOST PROFITS, OR INCIDENTAL DAMAGES FOR THE BREACH OF ANY WRITTEN OR IMPLIED WARRANTY WITH RESPECT TO THE FOREGOING DESCRIBED MERCHANDISE.

Model: MF2

Serial Number: \_\_\_\_\_

Date Received: \_\_\_\_\_

**EBAC LUMBER DRYERS  
SALES & SERVICE**

700 THIMBLE SHOALS BLVD  
SUITE 109  
NEWPORT NEWS, VA 23606-2575  
TELEPHONE: 757-873-6800  
TOLL FREE: 800-433-9011  
FAX: 757-873-3632

## Introduction

This Manual had been designed to guide you through constructing a suitable kiln chamber, and operating the kiln to obtain maximum output of wood.

Also included in this manual are directions and examples for sizing the chamber. We are always pleased to offer advice and assistance when required.

The purpose of the Ebac Lumber Dryer is to take moisture out of the air of an enclosed space containing lumber to be dried, thereby allowing the air to absorb more moisture from the lumber and subsequently speeding up the whole drying process.

Fans in the Lumber Dryer draw moisture-laden air over the evaporator coil where it is cooled. Since the evaporator coil temperature is maintained below the dewpoint of the air, water is formed on the surface which collects to run down the drain tray and out of the machine via the drain tube. The dehumidified air is then passed over the condenser coil where it is reheated before leaving the unit.

The air discharge is therefore drier and, as a consequence, slightly warmer than the air intake.

Being specifically designed for use in the elevated temperatures and low relative humidity's encountered when drying a wide variety of hard wood and soft wood, the Lumber Dryer will work continuously in temperatures up to 60°C (140°F) at 30% RH.

A heater is incorporated in the dryer for heating the lumber to the required temperature.

A control unit is a separate piece of equipment. It controls the drying and heating by use of signals received from the temperature and relativity sensing elements.

## LUMBER DRYING PRINCIPLES

When lumber is being dried, the rate of moisture evaporation is dependent on the difference between the vapor pressure of the wet wood and the vapor pressure of the air. When the vapor pressures have equalized, no further drying occurs. This is the point at which the equilibrium moisture content of the wood has been reached.

### EMC AT 68°F (20°C)

Figure 1

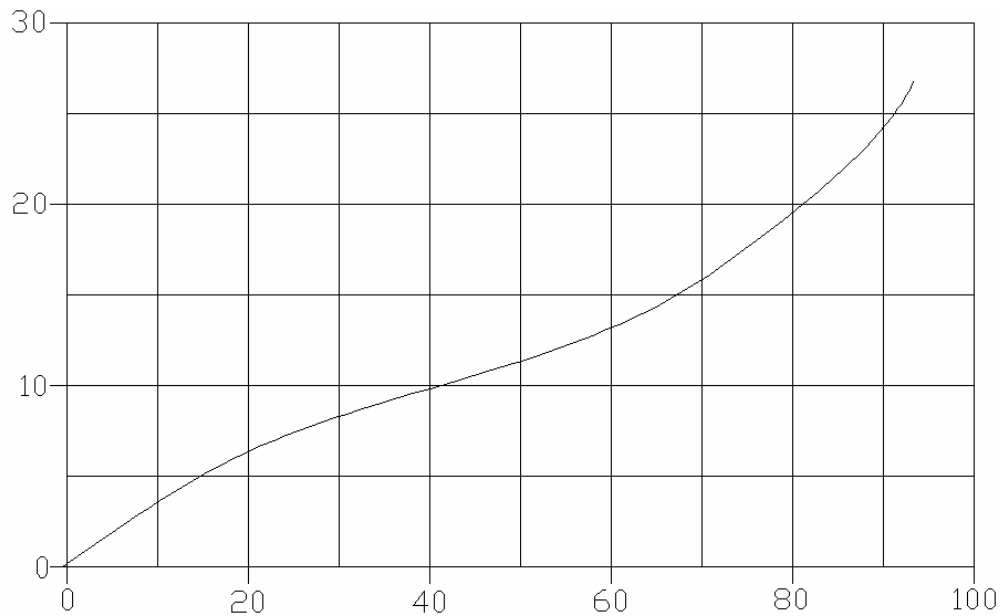

One way of increasing this vapor pressure difference and encouraging rapid drying, is to heat the wood and increase its vapor pressure. Essentially, this is what conventional steam kilns do.

Another way of increasing the difference between the vapor pressure of the air and that of the wood is to lower the pressure of the air. This is what Ebac dryers do; encourage evaporation by removing moisture from the air surrounding the wood.

As damp air is drawn into the machine (see Figure 2) water condenses onto a refrigerated coil. The water is drained off and the dried air is re-warmed with the heat from the condenser coil. The air is re-circulated through the lumber stack, causing more evaporation. Moisture-laden hot air is not simply vented into the atmosphere as in energy wasteful steam kilns; this results in efficient operation.

SIMPLIFIED SCHEMATIC DIAGRAM OF LUMBER COMPONENTS  
Figure 2

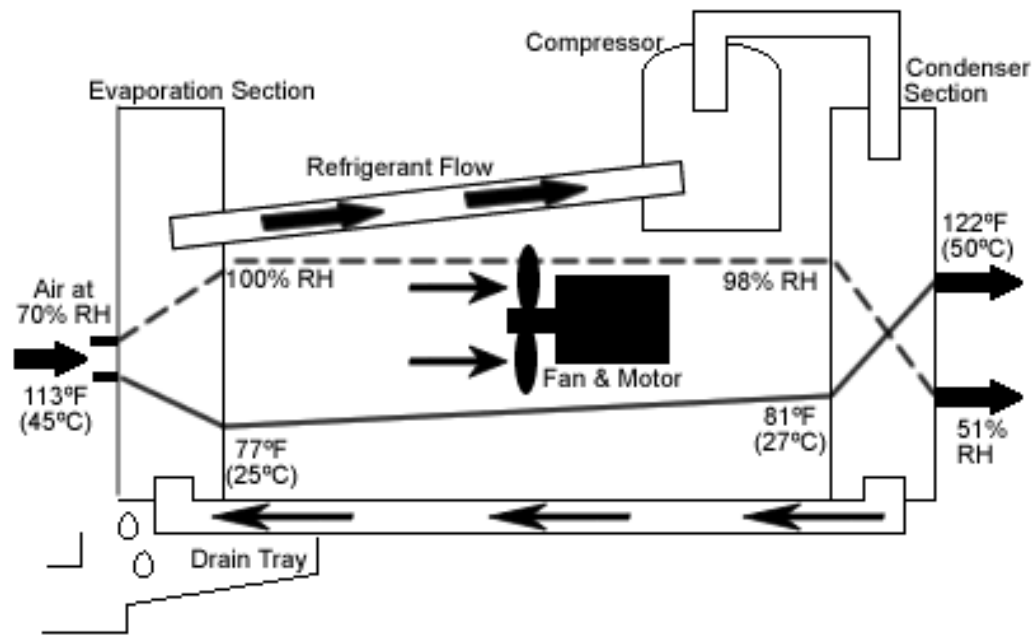

Though the fastest drying is achieved at high temperature, the risk of degrade in the wood, particularly hardwood, increases at high temperature. The general rule is that the lower the temperature the better the quality.

Ebac dryers are designed to operate in the temperature range which is the best compromise between speed and quality – about 140°F (60°C) and lower. Drying at these temperatures insures that the wood is of the highest quality, and that the equipment is reliable.

## KILN DESIGN AND CONSTRUCTION

### Stack Size Calculations:

The lumber stack size will depend primarily on the longest length board to be dried. Normally the length of the stack will be equal to the length of the longest board. If your lumber is in short lengths, then the stack length should be a multiple of these shorts.

The width and height of the stack can be adjusted to suit your conditions, for instance if you already have a standard package size.

In order to allow air flow through the lumber stack, each layer must be separated from that below by a spacer, or “sticker”. Typical “sticker” height is  $\frac{3}{4}$  for lumber up to 1  $\frac{1}{2}$ ” thick, and 1” to 1  $\frac{1}{2}$ ” for lumber greater than 1  $\frac{1}{2}$ ” thick. These air spaces thus created must be included in the overall stack height when calculating volume.

Listed below are steps to follow to design your kiln (use worksheet in Figure 3 for easy calculations):

1. Take the load size in BF and divide by 12 to obtain ft<sup>3</sup>. Then multiply by 1.75. This value (1.75) creates space for stickers.
2. Multiply the result from step 1 by 1.0. This allows 10% error since not all boards will be exactly the same length or stacked perfectly.
3. Divide the result from step 2 by the stack length.
4. Assume a stack width, usually 8 feet or less.
5. Divide the result from step 3 by the assumed stack width. Then round up to the next whole number, for the stack height.
6. If the stack width varies greatly from the stack height go back to step 4 and repeat, until the stack width and height are approximately equal.

**Example 1:** we will design the lumber stack for 5,000 BF of 1" lumber, 16' maximum board length.

<u>5,000</u>	TOTAL KILN BF	÷ 12	=	<u>416.7</u>	FT <sup>3</sup>
			X	<u>1.75</u>	Sticker Spacing
			=	<u>729</u>	FT <sup>3</sup>
			X	<u>1.10</u>	10% error allow in board length and stacking
	<b>STACK CALCULATIONS</b>		=	<u>802</u>	FT <sup>3</sup>
			÷	<u>16</u>	Stack Length (A)
			=	<u>50</u>	FT <sup>3</sup>
			÷	<u>8</u>	Stack Width (B)
			=	<u>6 ½</u>	Stack Height (C)

Stack Size = 16 (A) X 8 (B) X 6 ½ (C)

## Chamber Size:

Having calculated the stack size, it is now possible to calculate the appropriate internal dimensions of the chamber. This is done by adding the required additional space around the stack for the dryer and auxiliary fans, as well as for good air circulation.

The recommended additional spaces are as follows: 2 ½ ft behind the stack, 1 ½ ft in front of the stack, 3 ft above the stack, 1 ft on either end of the stack, and 6" in between stacks. These spaces are shown in Figures 4, 5 and 6.

These kilns will typically use 6" thick walls, doors, and ceiling. Add these dimensions to those already calculated for the outside dimensions of your kiln.

Example 2: Using the information from Example 1 where the stack size was 8' W x 6 ½' H x 16' L we can find the required internal and external dimensions:

### INTERIOR CALCULATIONS:

$$\text{Length} = \underline{16 \text{ (A)}} + \underline{2 \text{ FT}} = \underline{18 \text{ (D)}} \text{ FT} \quad \begin{array}{l} \text{-- 2 FT is for 1 FT distance on either side of stack -} \\ \text{- add 6" more between each stack} \end{array}$$

$$\text{Width} = \underline{8 \text{ (B)}} + \underline{4 \text{ FT}} = \underline{12 \text{ (E)}} \text{ FT} \quad \begin{array}{l} \text{-- 4 FT is for 2 FT - 6" behind the stack and 1 FT -} \\ \text{6" in front of the stack} \end{array}$$

$$\text{Height} = \underline{6\frac{1}{2} \text{ (C)}} + \underline{3 \text{ FT}} = \underline{9\frac{1}{2} \text{ (F)}} \text{ FT} \quad \text{-- 3 FT is for recirculating fans and false ceiling}$$

$$\text{Interior Size} = \underline{18 \text{ (D)}} \times \underline{12 \text{ (E)}} \times \underline{9\frac{1}{2} \text{ (F)}}$$

### EXTERIOR CALCULATIONS:

$$\text{Length} = \underline{18 \text{ (D)}} + \underline{1 \text{ FT}} = \underline{19 \text{ (G)}} \text{ FT} \quad \text{-- 1 FT is for 6 IN thickness on 2 sides of kiln}$$

$$\text{Width} = \underline{12 \text{ (E)}} + \underline{1 \text{ FT}} = \underline{13 \text{ (H)}} \text{ FT} \quad \text{-- 1 FT is for 6 IN thickness on 2 sides of kiln}$$

$$\text{Height} = \underline{9\frac{1}{2} \text{ (F)}} + \underline{6 \text{ IN}} = \underline{10 \text{ (I)}} \text{ FT} \quad \text{-- 6 IN is for ceiling thickness}$$

$$\text{Exterior Size} = \underline{19 \text{ (G)}} \times \underline{13 \text{ (H)}} \times \underline{10 \text{ (I)}}$$



1 2 3 4 5 6 7 8 9

A  
B  
C  
D  
E  
F  
G  
H  
I  
J  
K  
L

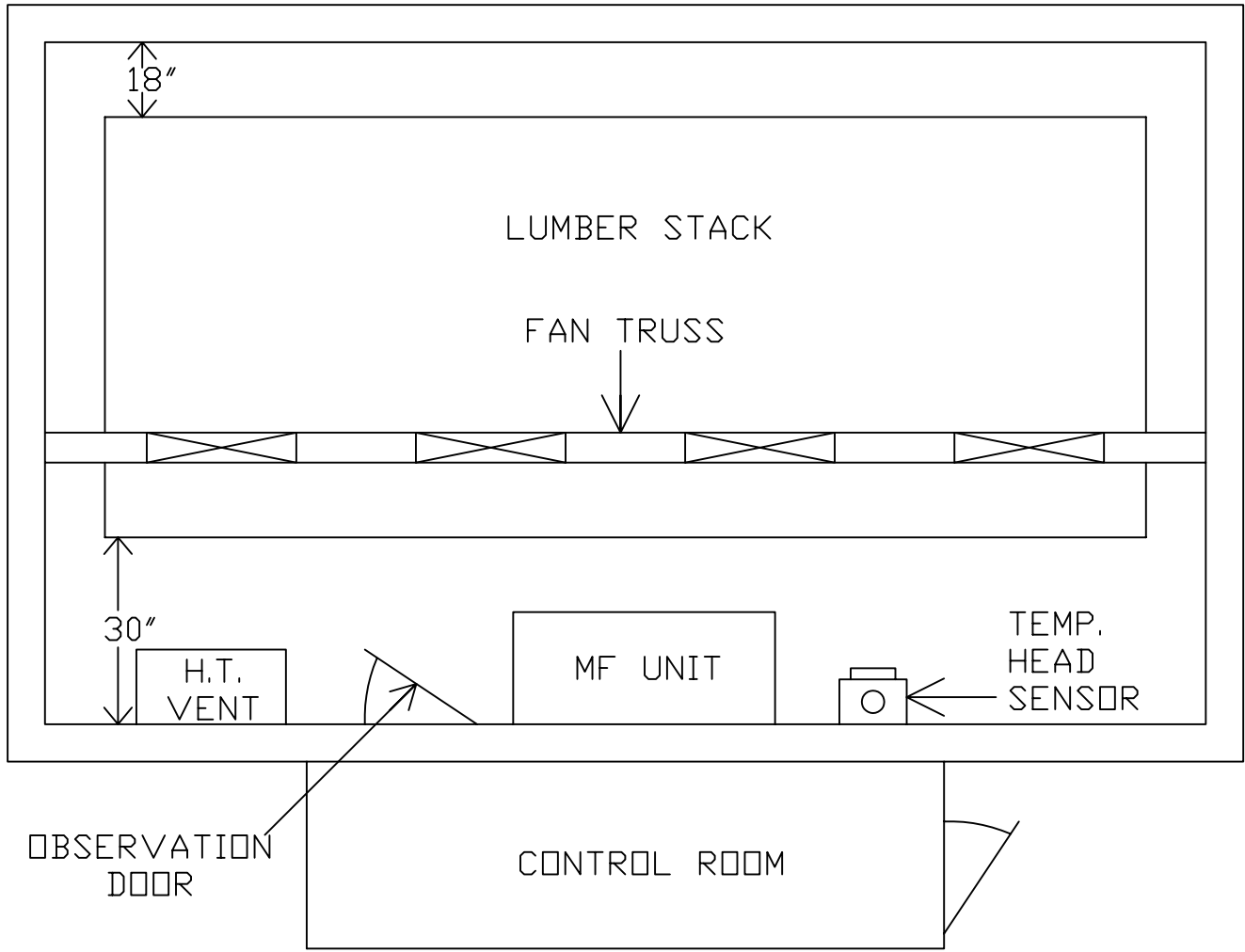

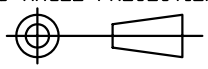
 <p>© 1993</p>	<p>LIMITED BISHOP AUCKLAND ENGLAND</p>	<p>TITLE MF KILN CHAMBER TOP VIEW</p>	
<p>3RD ANGLE PROJECTION</p>  <p>DO NOT SCALE IF IN DOUBT ASK</p>	<p>DIMENSIONS IN m.m. TOLERANCES UNLESS OTHERWISE STATED</p> <p>0. ± 1 0.0 ± 0.25 0.00 ± 0.05 ANGULAR ± 0.5 DEGREE</p>	<p>MATERIAL</p>	<p>DRAWN : C. LILLY CAD SCALE : NTS</p>
<p>FINISH</p>		<p>DRG.NO. FIG 4</p>	<p>SHEET 1 OF 1</p>

A4

FAN TRUSS DETAIL

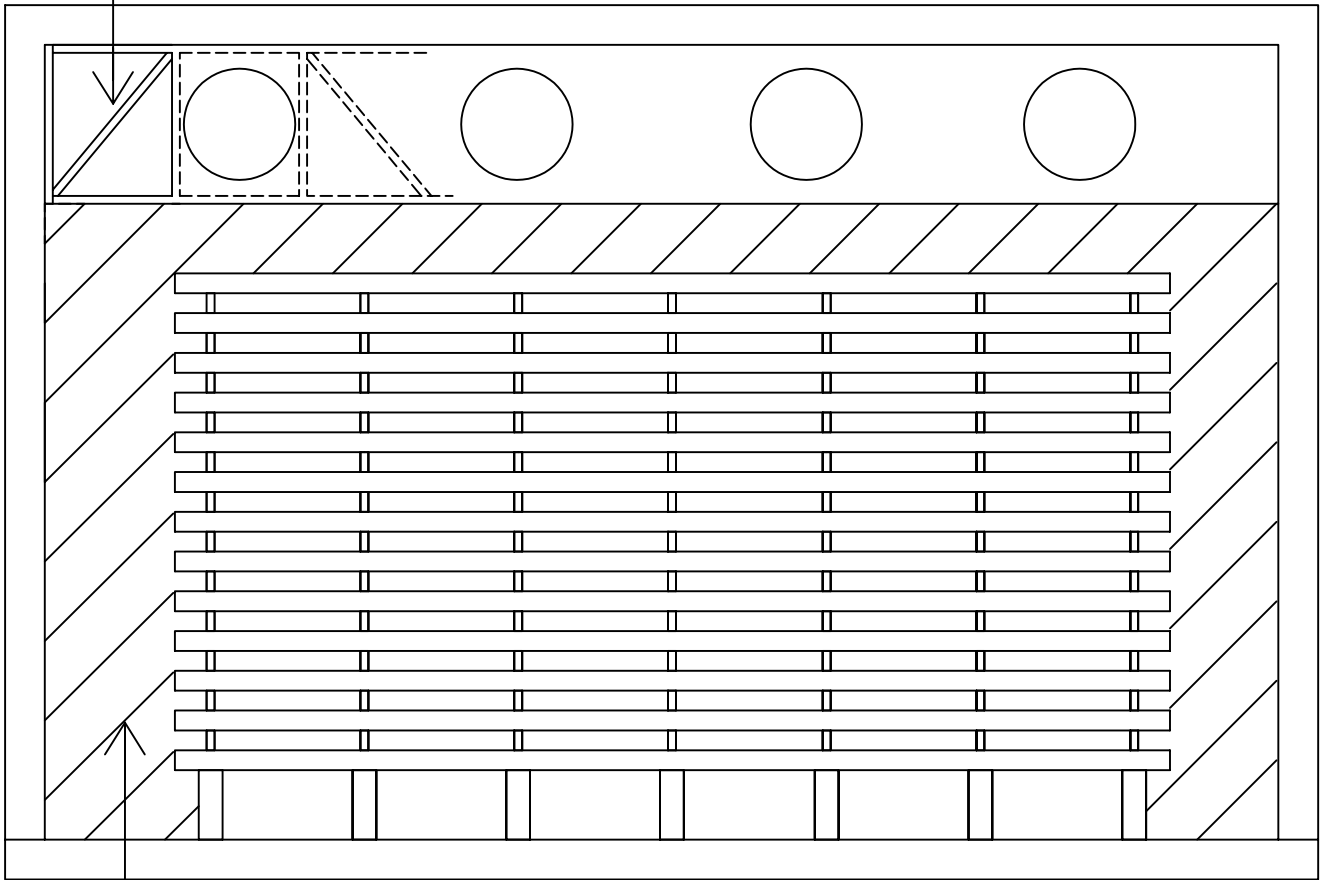

BAFFLE



LIMITED  
BISHOP AUCKLAND  
ENGLAND

TITLE MF KILN CHAMBER FRONT VIEW

3RD ANGLE PROJECTION

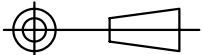

DO NOT SCALE  
IF IN DOUBT ASK

DIMENSIONS IN m.m.  
TOLERANCES UNLESS  
OTHERWISE STATED

0. ± 1  
0.0 ± 0.25  
0.00 ± 0.05  
ANGULAR ± 0.5 DEGREE

MATERIAL

FINISH

DRAWN : C. LILLY

CAD SCALE : NTS

DRG.NO.

FIG 5

SHEET  
1 OF 1

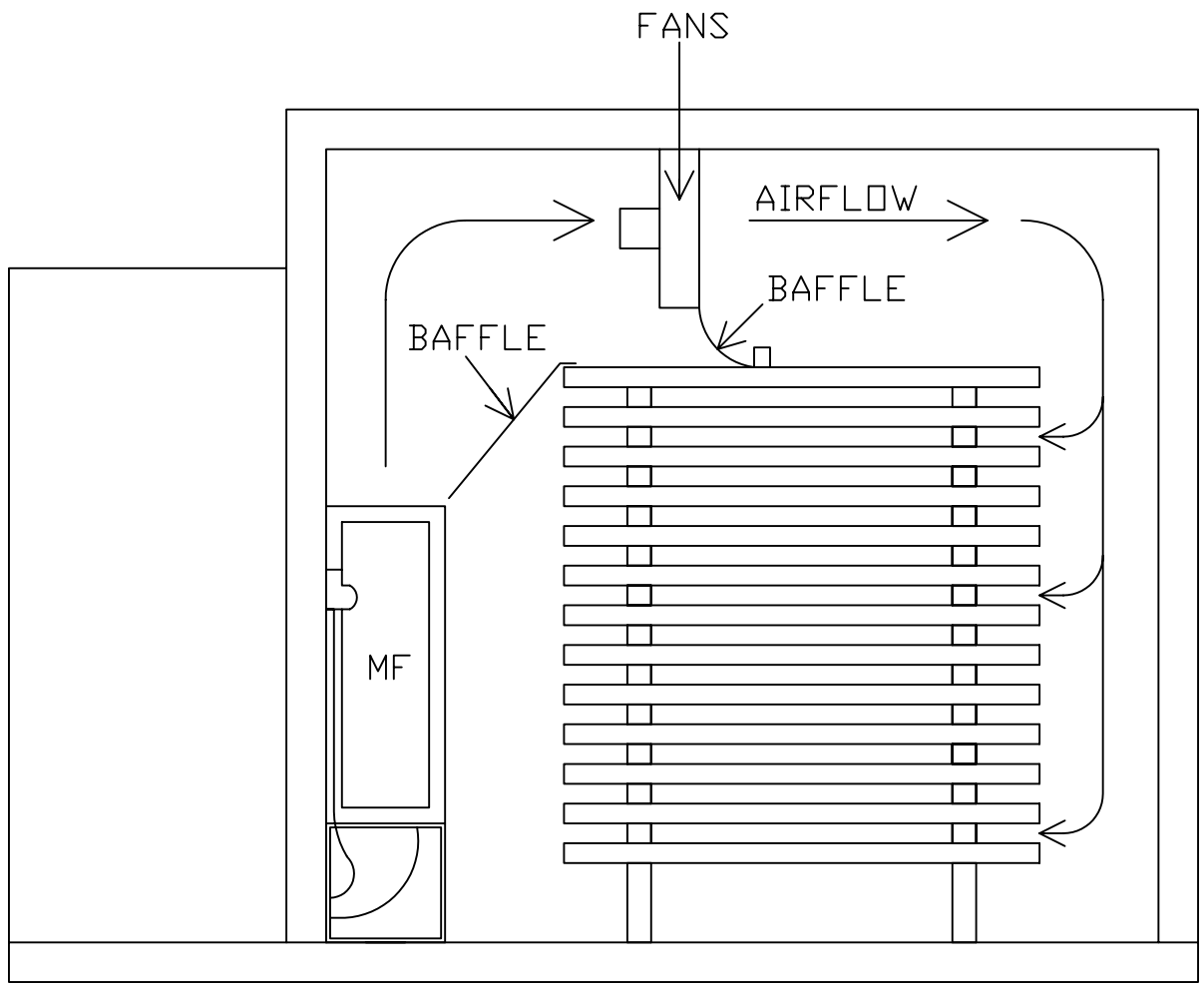

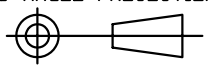
<p>© 1993 <b>Ebac</b></p>	<p>LIMITED BISHOP AUCKLAND ENGLAND</p>	<p>TITLE MF KILN CHAMBER END VIEW</p>	
<p>3RD ANGLE PROJECTION                    DO NOT SCALE                  IF IN DOUBT ASK</p>	<p>DIMENSIONS IN m.m.                  TOLERANCES UNLESS                  OTHERWISE STATED                  0. ± 1                  0.0 ± 0.25                  0.00 ± 0.05                  ANGULAR ± 0.5 DEGREE</p>	<p>MATERIAL</p>	<p>DRAWN : C. LILLY                  CAD SCALE : NTS</p>
<p>FINISH</p>		<p>DRG.NO.                  FIG 6</p>	<p>SHEET                  1 OF 1</p>

## **Kiln Construction:**

The walls and ceiling should be made of 2 x 6 frame construction filled with insulation (Styrofoam, fiberglass, etc. Approximately R24). The exterior surface should be ½" CDX plywood or corrugated metal. To provide a good vapor barrier, line the interior with polyethylene film and use tape to close all gaps and cover tack heads. On top of this polyethylene place ¼" gap around each sheet. Caulk these gaps, and then paint the entire kiln with manufactured kiln paint.

The floor should be an insulated concrete slab to provide structural support. First put down a gravel base, then 2" of rigid Styrofoam. On top of this place a layer of polyethylene, and finally a 4" reinforced concrete slab. This floor should have a slight pitch to a drain will allow you to remove that water directly, instead of cycling it through the machine.

The doors should be built just like the walls, an insulated 2 x 6 frame, a vapor barrier, and covered with plywood. They can be hinged on the sides, with a lap fit in the center. A heavy gasket should be placed on the inside edge of the door. This will ensure that the doors fit tightly against the kiln. The doors can also be hinged or rolled at the top or they can lift completely off. Latches can be any device which will pull the door snug to the kiln. (See Figure 7)

For all dry kilns, baffles or curtains should be provided above and to the side of the stack to force the air flow through the lumber stack, not around. Baffles can be anything that restricts the air flow, polyethylene works well.

You may also want to add a control room for your kiln. This is a room to house your control system, and to provide access to the kiln. This is also a convenient area to mount a remote moisture monitoring system. (See Figure 4).

Wire in 1 or 2 overhead lights, since it is typically quite dark in a kiln. These lights should be protected form high humidity, and damage by a cage and a glass cover. "Vapor-proof" lights are ideal.

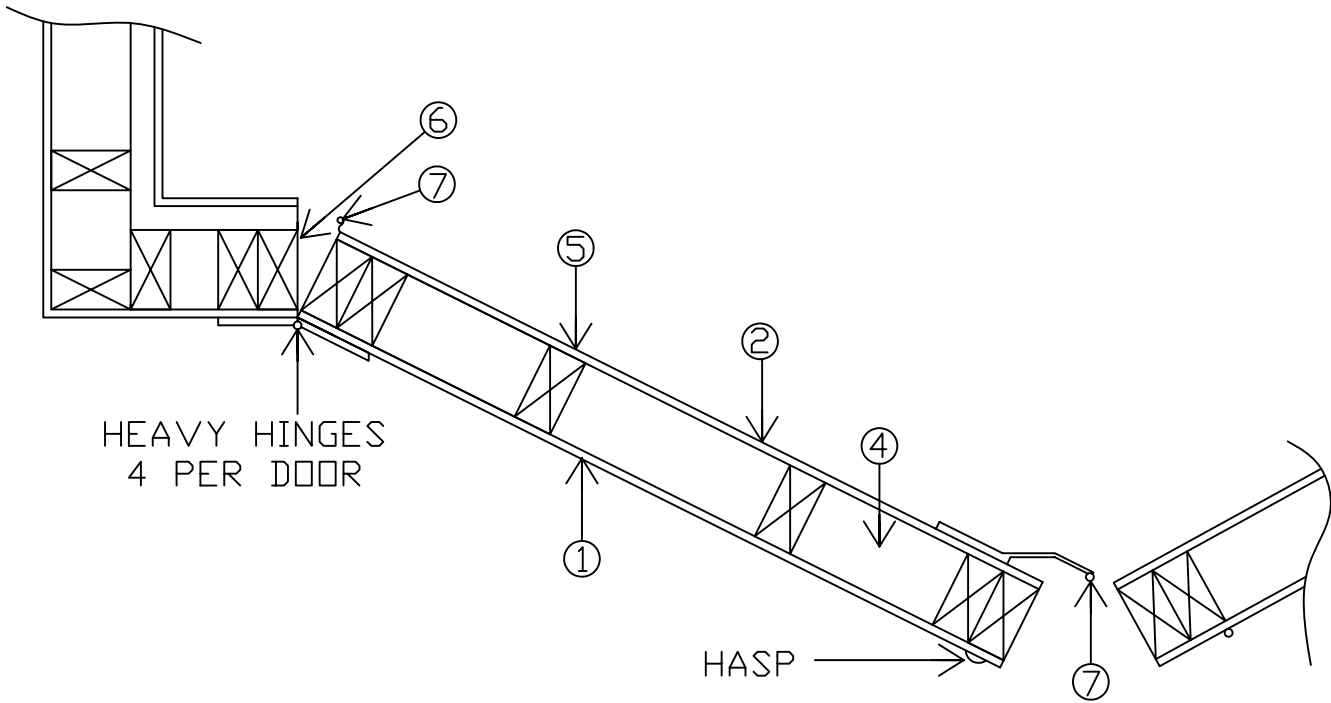

- 1 CDX PLYWOOD OR PARTICLE BOARD
- 2 4 MIL POLY
- 4 FIBREGLASS OR BLUE STRYROFOAM INSULATION
- 5 2X4 CONSTRUCTION
- 6 2X4 OR 2X6 CONSTRUCTION
- 7 RUBBER GASKET



© 1993

LIMITED  
BISHOP AUCKLAND  
ENGLAND

TITLE DOOR PLAN SECTION

3RD ANGLE PROJECTION

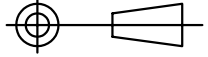

DO NOT SCALE  
IF IN DOUBT ASK

DIMENSIONS IN m.m.  
TOLERANCES UNLESS  
OTHERWISE STATED

0. ± 1  
0.0 ± 0.25  
0.00 ± 0.05  
ANGULAR ± 0.5 DEGREE

MATERIAL

FINISH

DRAWN : C. LILLY

CAD SCALE : NTS

DRG.NO.  
FIG 7

SHEET  
1 OF 1

## **MF Placement & Wiring**

The MF machine will be centered on the back wall, opposite the loading doors. This will leave about 1 ft between the machine and the lumber stack. (See Figure 4).

The sensing probes should be mounted at least 3 ft from the machine and about 5 ft above the floor.

When positioning the Lumber Dryer, care must be taken not to obstruct the air inlet and outlet. The air enters the base of the machine and is discharged from the top.

Remove covers to fit drain hose and install wiring between control unit and machine.

### **Drain lines:**

The drain tray is fitted under the aluminum finned evaporator coil at the base of the machine. Fit the drain hose onto the drain pipe and extend the drain hose down into the floor drain.

### **Wiring:**

Wiring should be carried out by a competent electrical contractor in accordance with local regulations.

The machine should be protected from harmful effects of voltage drop and single phasing by installing a suitable electrical panel.

The power supply is to be taken from the electrical panel to the master control unit, for connection into the power Input Terminal Block. See wiring diagrams for details. Power requirement is 220 Volt  $\pm$  10%, single phase, 60Hz.

Adequate grounding is required to the machine and the control unit.

## **Maintenance**

Your Ebac Lumber Dryer requires no routine maintenance but occasional cleaning of certain components will result in a more consistent performance. The evaporator and condenser coils should be cleaned, preferably with compressed air. Care must be taken not to damage the fins.

**IMPORTANT: NEVER USE STEAM CLEANING ON REFRIGERATION COILS**

Clean the drain tray, with particular attention to the drain pipe and hose, in order to ensure good drainage.

### **High Temperature Vent:**

The high temperature vent can be mounted almost anywhere inside the kiln, provided it is at least 3 feet above the floor. It is most commonly mounted on the back wall. (See Figure 4). You will need to construct a shroud outside the kiln to protect the vent from weather.

The Ebac exhaust vent is designed to automatically operate if the temperature in the kiln exceeds the thermostat setting on the controller.

If both shutters are mounted on the same wall, allow 6 feet minimum between the shutters. (See Figure 8 for installation instructions).

**WARNING: OSHA complying guards are strongly recommended when fans are installed within 7' of floor, working level, or within reach of personnel. Review OSHA codes.**

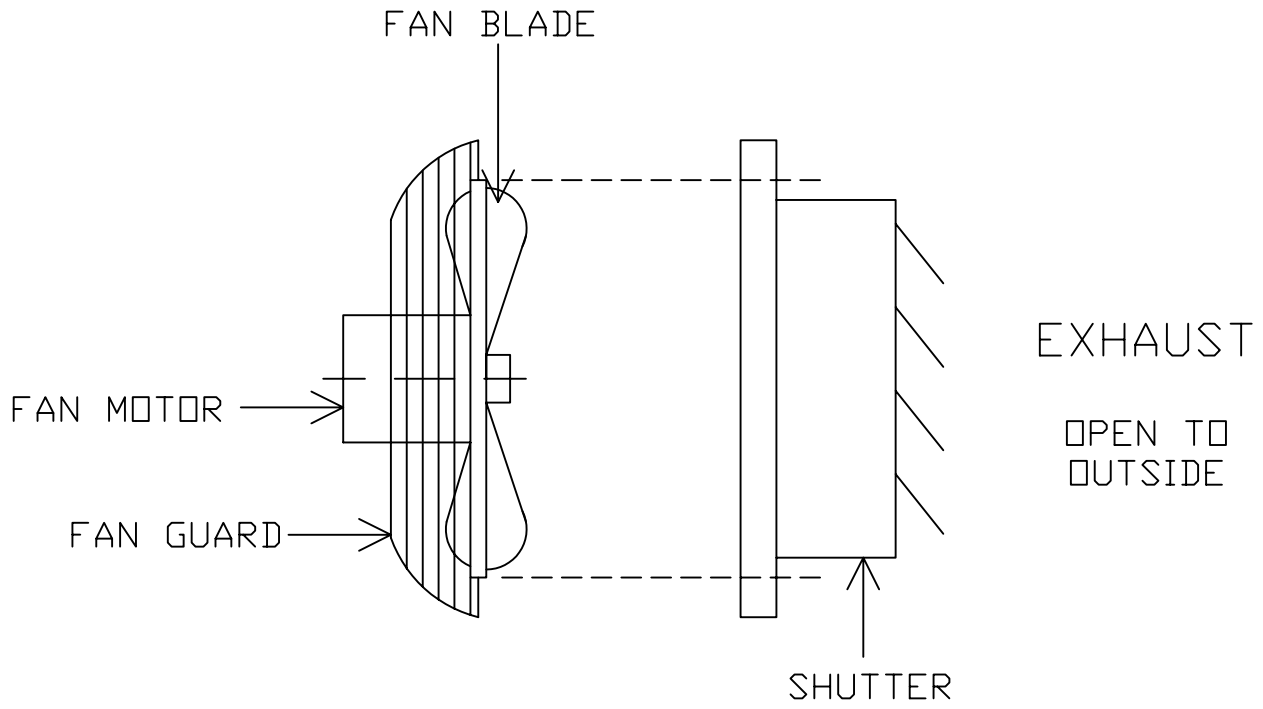

INTAKE  
OPEN TO  
INSIDE

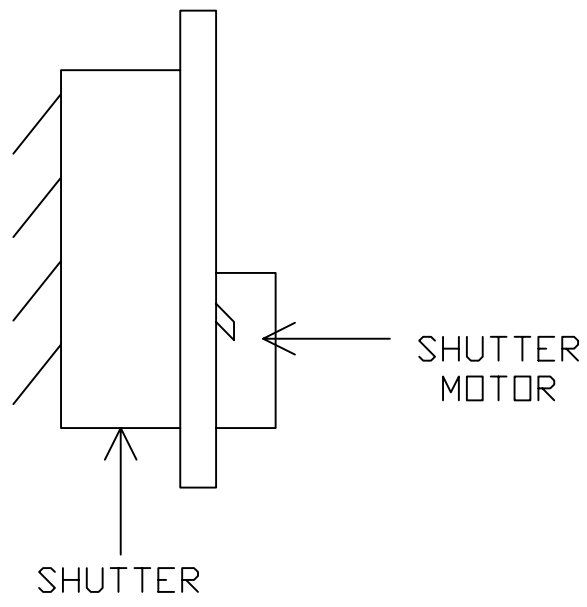

© 1993

LIMITED  
BISHOP AUCKLAND  
ENGLAND

TITLE  
MF'S HIGH TEMPERATURE VENT SYSTEM

3RD ANGLE PROJECTION

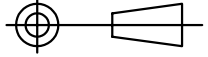

DO NOT SCALE  
IF IN DOUBT ASK

DIMENSIONS IN m.m.  
TOLERANCES UNLESS  
OTHERWISE STATED

0. ± 1  
0.0 ± 0.25  
0.00 ± 0.05  
ANGULAR ± 0.5 DEGREE

MATERIAL

DRAWN : C. LILLY

CAD SCALE : NTS

FINISH

DRG.NO.  
FIG 8

SHEET  
1 OF 1

## **Ebac Modular Control System**

### **Introduction:**

The main function of a process drying control system is to regulate the conditions inside the drying chamber.

Precise control is vitally important to the efficiency of the drying process in providing maximum quality, reducing costs, and increasing throughput.

Ebac MCU controllers are a family of units which can be supplied freestanding or, for larger installations, in a 19" rack system.

MCU control systems incorporate all of the safety and protection features you need, including:

1. Phase indicator lamps for all main components
2. Overload protection on fan motors
3. Independent switching of each drying unit
4. Circuit breaker protection of wiring

### **MCU1002 Control System:**

This system includes one MCU1002 process drying controller and an electro-mechanical temperature and humidity sensor. Adjustments to drying conditions are made within the drying chamber. The MCU1002 will provide the switching for one MF4 drying unit. A MCU1002 slave control unit is required for each additional dryer.

Features of the MCU1002 include "On" indicators for drying, heating, and cooling (venting), high temperature warning lamp, low humidity warning lamp, and phase indicator lamps for compressor, heater, fans, and cooling (vent).

# MCU1002 Control Unit

FRONT

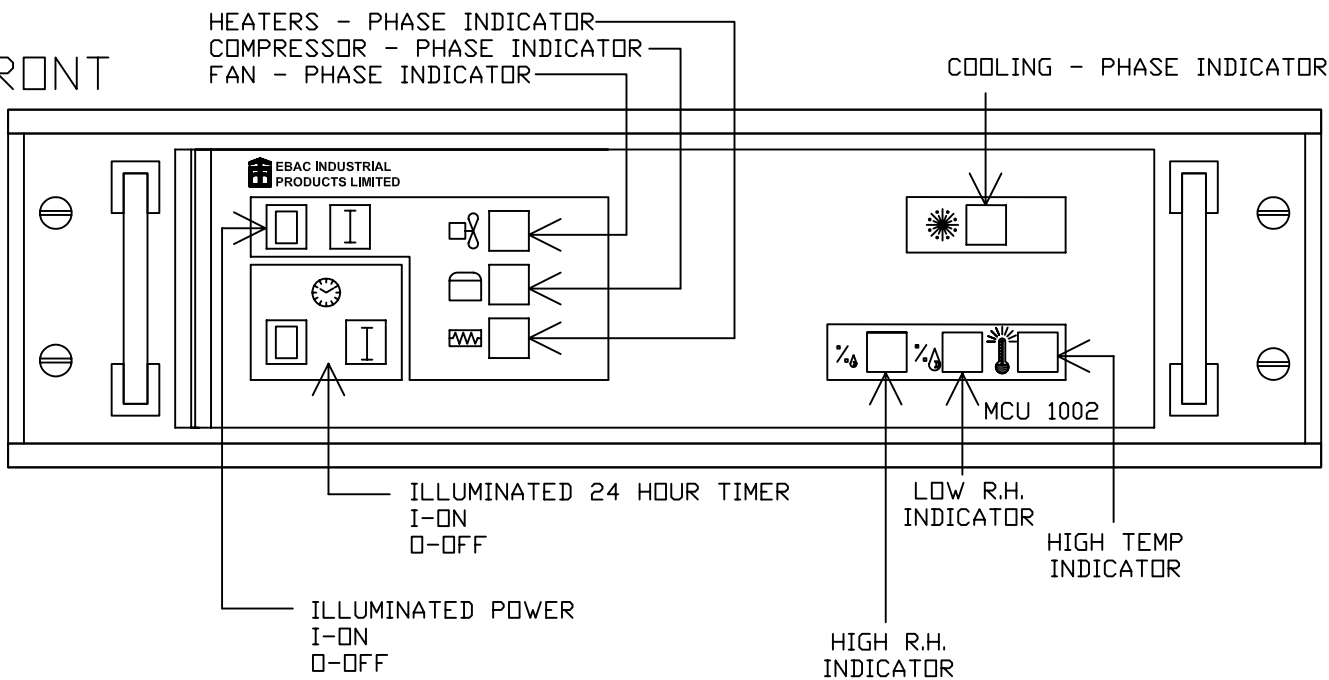

REAR

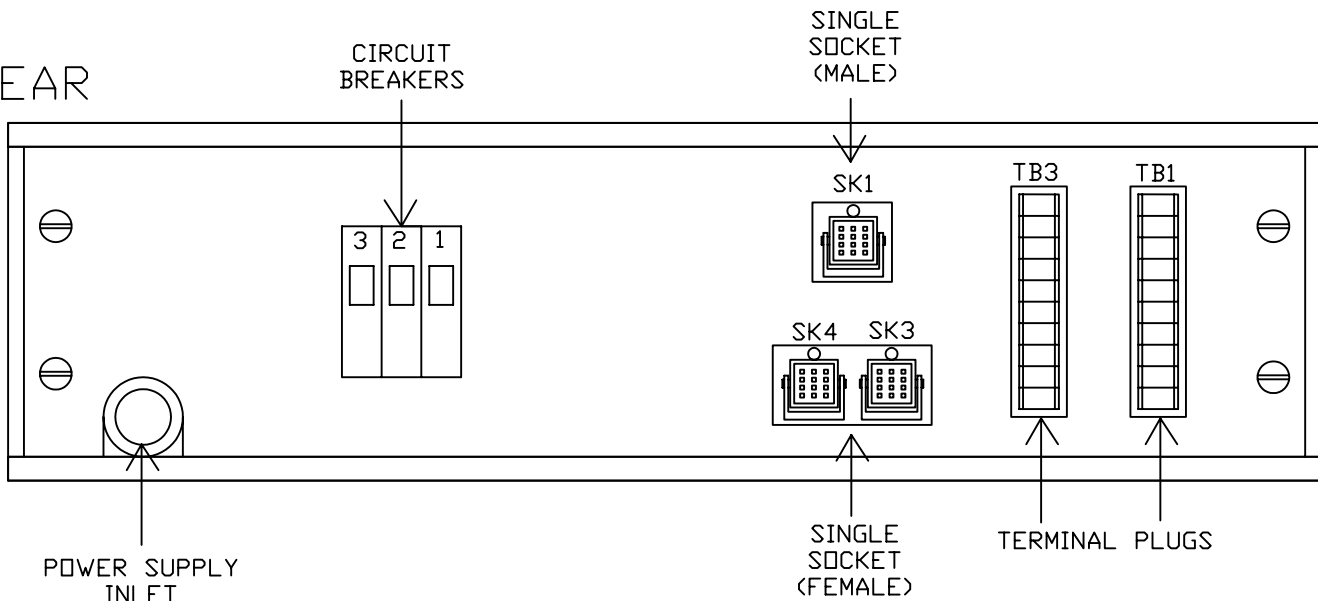

© 1993

LIMITED  
 BISHOP AUCKLAND  
 ENGLAND

TITLE  
 MCU 1002 CONTROL UNIT

3RD ANGLE PROJECTION

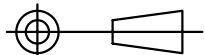

DO NOT SCALE  
 IF IN DOUBT ASK

DIMENSIONS IN m.m.  
 TOLERANCES UNLESS  
 OTHERWISE STATED

0. ± 1  
 0.0 ± 0.25  
 0.00 ± 0.05  
 ANGULAR ± 0.5 DEGREE

MATERIAL

FINISH

DRAWN : C. LILLY

CAD SCALE : NTS

DRG.NO.

FIG 10

SHEET  
 1 OF 1

A  
 B  
 C  
 D  
 E  
 F  
 G  
 H  
 I  
 J  
 K  
 L  
 A4

## Overview - MCU1002

The MCU1002 control module is designed to give effective drying, safe drying, extended life, simple operation and performance monitoring.

Effective drying is achieved by high quality relative humidity and temperature sensors.

Safe drying is achieved by including cross-over control. The dehumidifier section, the function of which is to reduce the relative humidity, can under certain climatic and internal conditions cause the temperature to rise to an undesirable level. This is avoided by an extra cutout switch controlling the dehumidifier on the thermostat, set slightly higher than the heater control switch. Similarly, the heater section can cause a fall in relative humidity. This is safeguard against by an extra cutout switch, controlling the heater, on the humidistat.

Extended life is achieved by the inclusion of a timer which obviates compressor rapid cycling. Switching the dehumidifier controls to "OFF" begin a time out sequence during, which the dehumidifiers compressor cannot restart.

Simple operation: Only two controls require adjustment.

Performance monitoring -- the MCU1002 control unit gives indication of the state of the machine under control.

1. Fans stop "0" indicates machine "OFF" and power "ON".
2. Fans start "1" indicates machine selected and power to sensor.
3. Low relative humidity indicates that heat has reduced the relative humidity, switching off the heater and compressor.
4. High relative humidity indicates sensors calling for dehumidification although timer may be delaying compressors switching on.
5. High temperature indicates temperatures too high switching off the heater and compressor.
6. Phase indicators indicate the appropriate control function is active and each phase is present.

7. 24 hour override timer stop "O" and start "I" indicates override not in use and override selected respectively.

The above indicators can be used to diagnose fault conditions should they occur. (See the Troubleshooting Guide).

### **24 Hour Override:**

This facility is used to increase the rate of initial heating where low relative humidity would otherwise switch off the heater.

### **Maximum Demand Reduction:**

An automatic facility switches off the heater for approximately three seconds whenever the compressors are switched "ON".

The MCU1002 Control Unit contains switch gear, contactors, overloads, and ancillary equipment necessary to control and operate one Ebac process dryer and cooling (vent). Further, dryers and coolers may be controlled by connecting and MCU1100 slave unit for each additional process dryer.

## Specifications - MCU1002

### Control Unit

Overall size including handles & connectors	6 ½" H x 19 ¼" W x 16 1/8" D
Case Size	6 ½" H x 19 ¼" W x 11 3/8" D
Weight	28 LBS.
Operating Voltage	230V / 60Hz / 1Ph or 240V / 60Hz / 3Ph
Operating Voltage Range	85% - 110%
Input Signal (Temperature)	24 VAC (+10% - 15%)
Input Signal (RH)	24 VAC (+10% - 15%)
Control Action	On/Off
Control Outputs	
Heat	220V / 60Hz / 1Ph or 3Ph – 24 Amp Max
Cool	<b>220V / 60Hz / 1Ph or 3Ph – 4A Min / 6.2A Max</b>
Dry	220V / 60Hz / 3Ph – 16 Amp Max
Data Output (TEI)	24 VAC

### Connections

Signal Output	8 way plug (supplied pre-wired with sensor)
Control Output	Screw terminal plug and socket

### Sensor Unit

Overall Size	13 ¾" H x 11" W x 4 ¾" D
Weight	6 Lb.
Temperature Sensor	2 stage differential thermostat
Differential	Adjustable 2°C - 10°C
Range	10°C - 94°C
R H Sensor	2 stage differential humidistat
Differential	Adjustable 2% - 20%
Range	10% - 100%
Scale Division:	10%

## Installation - MCU1002

### **Unpacking & Pre-Installation Check:**

Unpack the equipment and check the contents:

1. Control Unit complete with TB Plugs
2. Sensor Unit
3. Interconnecting Cables

Check Overload Settings: Remove chassis from case by removing TB plugs from the rear of the unit, remove front fixing screws and withdraw chassis.

Overload O/L1 set at -- 2.4A

Adjust overloads if required and press red reset button to ensure reset. Slide chassis back into case and secure with fixing screws.

### **Mounting:**

The control unit is a free standing unit for desk or shelf mounting outside the drying chamber. The sensor unit is a wall mounting unit to be fixed in a convenient position within the drying chamber. Fixings are not supplied.

### **Electrical Connections:**

The electrical installation should be carried out by a competent electrical engineer in accordance with local and national regulations. All the cables should be suitably sized with due regard to load and ambient temperature.

Connect the control unit to a suitable, isolated power supply. The power terminals are located at the rear right of the unit and are accessed by removing the rear cover. Ensure the ground wire is terminated to the ground stud below the terminals.

Connect the process dryer to the control unit via the terminal plug and sockets TB1/TB2. See appropriate interconnecting diagram.

Connect the Overheat Vent/Cooling Unit to the Control Unit via the terminal plug and socket TB3. See appropriate interconnecting diagram.

Where additional modules are used, interconnect by connecting socket SK3 to socket SK1 and socket SK4 to socket SK2 between each adjacent module using the cables supplied.

Connect the cable from the sensor unit into socket SK1 on the rear of the unit.

### **Calibration - MCU1002:**

#### Humidistat

1. Unscrew the box cover
2. Measure the relative humidity close to the hair element with a psychrometer.
3. Turn the indicator knob to the measured value.
4. Turn the calibrating nut to a position where the fixed switch clicks (that switch which clicks at a higher scale value when turning the knob.) Then make a fine adjustment of the nut position until this micro switch clicks on both sides of the present humidity value when the knob is turned slightly to-and-fro around the present value.
5. Turn the indicator knob 10% lower and adjust the differential screw until the second micro switch clicks.
6. Try out the automatic functioning of the switched under normal working conditions and make adjustments if necessary.
7. Turn the indicator knob to the required control setting and replace the box cover.

## Operation - MCU1002

1. Adjust the temperature sensor (thermostat) to the required temperature setting.
2. Adjust the humidity sensor (humidistat) to the required RH setting.
3. Ensure the main power isolator is in the “ON” position. The red stop indicators on the left side of the Facia will be illuminated.
4. Press the green fan start (I) push button, adjacent to the fan symbol, which will illuminate.
5. The control unit is now operational and will automatically control the drying unit and overheat vent (cooling unit).
6. 24 Hour Override: This overrides the heaters being off due to low RH and may be used if the initial heating is too slow.

Pressing the 24 HOUR OVERRIDE START (I) push-button will bring the heaters “ON” for 24 hours or until the required temperature is reached. After 24 hours the override will reset to “STOP”. Pressing the 24 HOUR OVERRIDE STOP (O) push-button will reset the override to STOP at anytime during the 24 hour period.

Normal caution should be exercised when using this override and it should not be used if the chamber is heating at a rate of more than 0.5°C per hour.

7. The MCU1002 Facia incorporates four 3 – phase indicator lamps. These lamps indicate that power is available to the circulating fans, compressor unit and heaters of the drying unit and to the cooling unit (overheat vent).

During normal operation, each of the three phase indicator lamps must be illuminated, provided that the control unit is calling for activity of that particular function. If one or two lamps, only in any line of three, are illuminated press the red fan stop (O) push-button immediately and consult the fault finding guide.

8. To terminate operation, press red fan stop (O) push-button.

## Maintenance - MCU1002

### Humidistat:

If dust or other matter is allowed to accumulate in any sensory element (made of hair, plastic, cotton, wood, or other material) its hygroscopic interchange with the surrounding air is weakened. So remove the dust or other light accumulation at regular intervals by using a soft brush.

Reviving (washing of the hair section) should not be done if the humidistat is functioning normally. It should be done only if the regulating precision becomes erratic (e.g.; as would happen if the hairs became coated with grease).

If the sensory element of the humidistat gradually acquires a heavy coating, the hygroscopic interchange with the surrounding air ceases. The element must then be unhooked and cleaned.

To unhook -- Turn the indicator knob to the lowest setting (30%) to slacken the hair element. Pry open the shorter end of the spring clips (one at each end of the pair of hair sections) and extract the sections carefully by the end tabs. Wash the hair element (e.g. with hair shampoo and lukewarm water) until the dust or grease is removed. Then rinse thoroughly in pure water. Re-hook both sections of the hair element onto the humidistat without touching the strands of hair with the fingers. Set the indicator knob to the highest setting. Calibrate when the hair element is dry. Check the calibration (and if necessary, re-calibrate) after a few days.

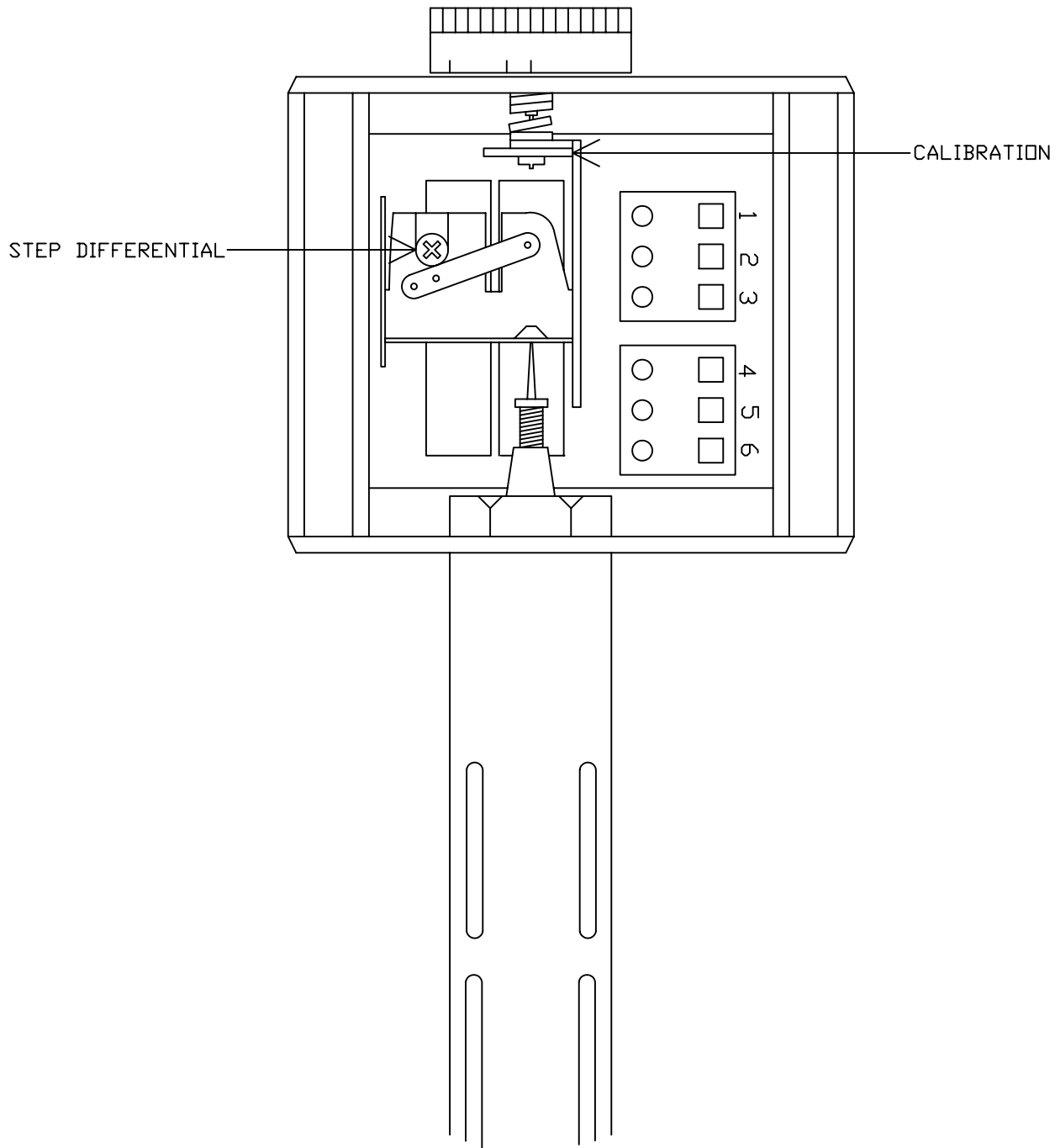

LIMITED  
BISHOP AUCKLAND  
ENGLAND

TITLE HUMIDISTAT

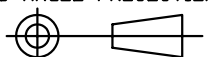
3RD ANGLE PROJECTION  
  
 DO NOT SCALE  
 IF IN DOUBT ASK

DIMENSIONS IN m.m.  
 TOLERANCES UNLESS  
 OTHERWISE STATED  
 0. ± 1  
 0.0 ± 0.25  
 0.00 ± 0.05  
 ANGULAR ± 0.5 DEGREE

MATERIAL

DRAWN : C. LILLY  
 CAD SCALE : NTS

FINISH

DRG.NO.  
 FIG 11

SHEET  
 1 OF 1

## Spare Parts List -- MCU1002

Description	Ebac Part No.	Quantity Per Unit
Push-button Switch	3030697	4
Lamp Holder	3034547	3
Lens - Green "I"	2314513	2
Lens - Red "O"	2314514	2
Lens - White	3034551	3
Lamp	3034548	7
Neon (Phase) Indicator	3034549	12
Circuit Breaker 10A	3032919	1
Circuit Breaker 16A	3032927	1
Circuit Breaker 25A	3032928	1
Socket Housing	3033812	3
Male Insert	3033809	1
Female Insert	3033810	2
Terminal Block (4 Way)	3031418	1
Terminal Plug	3031497	3
Terminal Socket	3031498	3
Clamp	3031499	3
Contacto 9A	3030321	2
Contacto 16A	3030322	2
Aux. Contact N/O	3030354	7
Aux. Contact N/C	3030350	1
Transformer (48VA)	3031136	1
Varistor	3033118	8
P C B Assembly	1608700	1
Overload Relay (2.7A - 4.2A)	3032647	1
Overload Relay (4A -6.2A)	3032635	1
Sensor Assembly	1318500	1

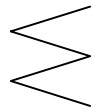

TOTAL



24 HOUR TIME



FAN



COMPRESSOR



HEATER



DRY



HUMIDIFY



COOL



HIGH RELATIVE HUMIDITY



LOW RELATIVE HUMIDITY



HIGH TEMPERATURE



© 1993

LIMITED  
BISHOP AUCKLAND  
ENGLAND

TITLE

KEY TO FACIA SYMBOLS

3RD ANGLE PROJECTION

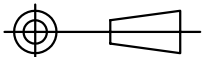

DO NOT SCALE  
IF IN DOUBT ASK

DIMENSIONS IN m.m.  
TOLERANCES UNLESS  
OTHERWISE STATED

0. ± 1  
0.0 ± 0.25  
0.00 ± 0.05  
ANGULAR ± 0.5 DEGREE

MATERIAL

DRAWN : C. LILLY

CAD SCALE : 1/1

FINISH

DRG.NO.

FIG 12

SHEET  
1 OF 1

# **MCU1100 Control Unit**



## Overview -- MCU1100

1. The MCU1100 contains all of the switch gear, overloads, contactors, relays and ancillary equipment necessary to enable one Ebac Lumber Dryer to operate correctly. The above components are not installed inside the drying unit where temperature and humidity conditions could be harsh leading to failure. An MCU100 is required for every drying unit installed within the chamber.
2. The MCU1100 interprets signals from the control panel and switches on or off the various functions of the Ebac drying unit. (e.g.):
  - Internal fans within the drying unit.
  - Refrigerant compressors used in the drying operation.
  - Internal heaters within the drying unit.
  - Cooling system operation.

The activity of each function is indicated by three phase lamps located on the module facia.

3. A red stop button and a green start button can be used to start respective drying unit independently of the other drying units in the system.
4. The phase indicator lamps together with the illuminated start and stop buttons can be used to diagnose abnormal conditions should they occur. Please consult the troubleshooting guide if necessary.

## Installation - MCU1100

1. The MCU1100 is available as a free standing module or may be incorporated inside rack housing. The unit should be installed by a competent electrical contractor in accordance with local regulations. Wiring sizes quoted are minimum sizes.
2. Connect to an adequate isolated power supply by running three phase and a ground wire to the main terminal block situated on the extreme left of the rear of the unit. Minimum conductor size is #8 AWG cu.
3. Ensure the ground wire is connected to the ground stud adjacent to the main terminal block.
4. Connect two control leads from the module positioned above to the fixed plugs 1 and 2 on the rear of the MCU1100 module. Ensure securing catches are pressed fully home.
5. Where additional modules are connected to a common control system, connect two further control leads from sockets 3 and 4 on the module to fixed plugs 1 and 2 on the next module.
6. Repeat step 5 until every module in the system has been linked together in series. Ensure all plugs and sockets are tightly secured.
7. Remove free socket located in the terminal TB1. Using conductors with a minimum size of #14 AWG cu, connect each terminal on the free socket to the MF4 Lumber Dryer terminal block. Ensure terminals are connected in accordance with the following:

<u>Free Socket Terminal</u>	<u>to</u>	<u>MF2 Terminal Block</u>
1		1
2		2
3 Not Used		3 Not Used
4		4
5		5
6		6
7		7
8 Not Used		8 Not Used
9		9
10		10

8. Remove free socket located in the terminal TB3. Using conductors with a minimum conductor size of #14 AWG cu, connect the high temperature vent system as shown on the MCU1100 single phase wiring diagram:

<u>Free Socket Terminal</u>	<u>to</u>	<u>High Temperature Vent Motors</u>
1		Connect this to Vent Motors
2 Not Used		
3		Connect this to Vent Motors
4 Not Used		
5 Not Used		
6 Not Used		
7 Not Used		
8 Not Used		
9 Not Used		
10 Not Used		

9. Ensure that the 16 amp, 25 amps, and 10 amp circuit breakers on the rear of the module are switched to the “ON” (I) position.

## Operation -- MCU1100

1. Ensure main power circuit breaker is in the "ON" position.
2. The RED stop switch on the right-hand side of the facia will be illuminated.
3. Press the GREEN start switch on the right-hand side of the facia which will become illuminated. If this does not occur, consult the fault finding section.
4. Repeat steps 2 & 3 with every MCU1100 module incorporated in the system, this will initiate operations of each of the Lumber Drying units installed within the drying chamber. If appropriate, for example, when drying less than a full load of product you may elect not to use all of the lumber dryers installed, in such instances follow step 3 for only drying units you intend to operate.
5. The MCU1100 front panel incorporates 12 phase indicator lamps. These lamps indicate that power is available to:
  - Fans inside the drying unit - depicted by a fan emblem
  - Refrigerant compressor unit - depicted by a compressor emblem
  - Heater inside the drying unit - depicted by a resistance symbol
  - Cooling section - depicted by a frost symbolDuring normal operation each of the three phase indicator lamps must be illuminated, **provided** that the control unit is calling for activity of that particular function. If one or two lamps, only in any line of three, are illuminated, press the RED stop button immediately and consult the Troubleshooting Guide.
6. To terminate operation of one or more drying units, for example at the end of the run, press the RED stop button(s).

## **Drying Lumber**

Lumber drying, like all drying, is a process of evaporation and occurs at the surface of the wood when the vapor pressure of the air is less than that of the lumber. The greater this difference, the greater the evaporation rate and the greater the rate at which the surface dries. As the surface dries, moisture migrates from the heart of the wood in order to try and equalize the now differing vapor pressures co-existing in the wood. If the differential set-up between the core and the surface of the wood is too great, the surface will shrink too quickly relative to the core, resulting in stresses which lead to most of the problems encountered in lumber drying.

The object of good lumber drying is to make the drying gradient as steep as possible without causing damage to the wood. This is done by regulating the evaporation rate - through control of air temperature and humidity - lowering the relative humidity of the air in accordance with the decreasing moisture content of the wood. So, to dry lumber effectively, its moisture content needs to be monitored throughout the drying process.

Before placing the lumber in the chamber, the initial moisture content of the wettest boards should be measured by means of an electronic moisture meter or the oven dry method. This is necessary in order to follow the drying schedule.

### **Determining Moisture Content:**

The amount of moisture in a piece of wood is known as its moisture content. This quantity is expressed as a percentage of the dry wood weight only, not as a percentage of the total. The weight of water in a given piece of wood may be heavier than the actual weight of the wood itself, in which case the moisture content would be over 100%. It is calculated by the formula:

$$\frac{\text{Weight of water in a sample}}{\text{Weight of dry sample}} \times 100\% = \text{Moisture Content}$$

Electronic meters measuring the electrical resistance of wet wood may be used to determine the moisture content of wood below 30% MC, but above this percentage the electrical resistance of wood does not vary so dramatically with the amount of moisture, and so is not an effective index of high moisture content levels.

The oven drying method of moisture content determination should be used for wetter wood, the procedure is given in Appendix I.

### **Drying Rate:**

It is essential to note that the drying rate varies for different lumbers. Some lumber can be dried at 10% per day, while others cannot satisfactorily exceed 1% per day. Following the relative humidity's given the schedules, which are conservatively estimated, will result in drying at a safe rate, which is not necessarily, or even usually, the fastest safe rate possible. This faster rate should be found by the operator's experience of the particular characteristics of his kiln and the lumber he deals with. The relative humidity's given may be reduced by up to 15% without substantially increasing the risk of splitting and case hardening etc., although normal caution should be exercised.

### NOTES:

1. The drying rate is greatly influenced by the thickness of the wood. If a stack of lumber is replaced with a stack of the same volume but made up of thicker planks, the surface area on which the evaporation takes place will be reduced. Therefore, evaporation will be less and drying times longer. Since the evaporation is reduced, the water extraction rate is reduced.

To compensate for the increased drying time, the volume of lumber dried per load should be increased. This will maintain the volume dried per year and will enable full utilization of the water extraction capacity of the dehumidifier.

It can be seen from the graph that to maintain the example drying rate for lumber twice the thickness, it is necessary to double the load.

2. If the RH setting were left unchanged during the kiln run, the dehumidifier would be on for a shorter period each day as the lumber dried and the vapor pressure difference between the air and the lumber decreased. By the use of the schedules for temperature and humidity this is avoided. The aim should be to have the dehumidifier running the same number of hours per day, by calling for a lower RH as the vapor pressure differentially drops. The schedules may have to be adjusted accordingly.
3. If the wood dries too quickly and checks in the surface or case-hardening occur, the wood must be subjected to higher humidity's which will soak into the wood and alleviate the problem.
4. Should a stack of lumber undergo uneven drying, it is most likely a sign of uneven or inadequate airflow, and action must be taken to ensure even airflow through the stack, particularly with reference to the edge of the stack where the air enters, which should be neatly in line.

The lumber stack should, of course, be built with sticks between layers to allow circulating air through the stack. These should be directly, beneath one another to reduce stress on the lumber and allow untrammelled air flow. If the sticks are too thick, they will create too easy a route for the air from the lumber dryer which will then tend to flow through the bottom of the stack at the expense of the rest. If the thickness of the sticks is reduced, more pressure will be created between layers, forcing the air to spread out and pass through all layers equally.

## **Preparation of the Lumber Stack:**

The best lumber drying results are obtained when the load of the lumber is of the same species, quality, thickness and initial moisture content. However, this is not always possible. In such situations, the drying procedure should follow the slowest wood in the load -- i.e., the hardest, thickest or wettest boards.

The layers of lumber are separated by stickers. The thickness of the stickers is determined by the thickness of lumber most commonly being dried. Stickers of  $\frac{3}{4}$ " are generally used with boards up to  $1\frac{1}{2}$ " thick and stickers of  $1\frac{1}{2}$ " for boards thicker than  $1\frac{1}{2}$ ". In practice, one set of stickers can be used in a kiln no matter what the lumber thickness.

The layers of stickers should be placed directly above each other to prevent distortion of the boards during drying. The space between columns of stickers should be approximately 18" to 30" for board thickness up to  $1\frac{1}{2}$ " and 24" to 48" for board thickness greater than  $1\frac{1}{2}$ ". Put a column of stickers at each end of the stack to support the ends and help reduce end splitting. The important consideration is that the boards do not sag between rows of stickers.

Gaps in the same stack cross-section are reduced by using boards of the same length, which otherwise would result in a non-uniform circulation at these spots. It is also important for good air circulation to fill the chamber to full capacity. If this is not possible, any gaps and spaces should not be blocked with baffles so that air passes through the stack and not around it.

## **Kiln Operating Instructions:**

1. Determine the Drying Group and Schedule for the species to be dried. This is found in Table I.
2. Measure the average moisture content (MC %) of the lumber being placed into the kiln.
3. Look up the appropriate drying schedule (A-L) in Table II. Determine the initial temperature and relative humidity settings to start your kiln run.

All the lumber in the kiln should be the same species, thickness and moisture content. If not, use the schedule with the lowest temperature and highest RH settings.

4. Switch on the overhead circulation fans.

5. Set the relative humidity (RH %) to the initial schedule setting.
6. To set the temperature, check the kiln air temperature. Set the thermostat 25°F (14°C) higher than this, but in no case higher than the beginning kiln temperature in the appropriate drying schedule.

Increase the kiln temperature by 25°F (14°C) every 24 hours until the beginning kiln temperatures from the appropriate drying schedule is achieved. The heating up process takes from a few hours to a few days depending upon starting temperature.

Whenever the thermostat setting during the heating up process below 95°F (35°C), press the RH% over-ride button. This defeats the low RH% crossover control for 24 hours and allows the kiln to heat up.

Only rare circumstances should require the over-ride button to be pressed at kiln temperatures of 95°F (35°C) or more. It never should be pressed once the schedule temperature is reached. This procedure reduces any chance of degrade.

7. Check the lumber moisture content (MC %) every day or two and adjust the temperature and RH settings per the schedule as the average lumber MC% drops through the drying cycle.
8. After the drying process is complete, the drying equipment should be switched off and the chamber allowed to cool until the temperature of the lumber is not more than 40°F (22°C) higher than outside air temperature.

The overhead circulation fans continue running during this process.

# KILN PROGRESS SHEET

**Table I****Drying Group / Schedule**

<b><u>SPECIES</u></b>	<b><u>GROUP</u></b>	<b><u>SCHEDULE</u></b>	<b><u>lbs/cu ft FOR 1% MC</u></b>
Abura	3	K	0.31
Afara	4	J	0.30
Afromosia	5	J	0.38
Afzelia	9	E	0.50
Agba	4	J	0.29
Alder	4	J	0.29
Apitong	7	D	
Apple	6	A	0.39
Ash	6	D	0.38
Aspen	3	K	0.35
Balsa	2	H	0.09
Basswood	3	K	0.26
Beech	5	D	0.40
Birch, European	3	F	0.36
Birch, American	5	F	0.38
Bitangor	5	A	0.38
Butternut	8	D	0.27
Camphor	8	G	0.33
Cedar, Virginian	3	H	0.26
Cedar, Western Red	2	J	
Chengal	8	B	
Cherry	5	A	0.33
Chestnut	8	D	0.30
Corida	4	K	0.24
Cypress	2	K	0.25
Dahoma	7	A	0.38
Danta	8	E	0.41
Durian	5	D	
Ebony	7	C	0.56
Ekki	9	B	0.57

**Table I**  
(Continued)  
**Drying Group / Schedule**

<u>SPECIES</u>	<u>GROUP</u>	<u>SCHEDULE</u>	<u>lbs/cu ft FOR 1% MC</u>
Elm	5	A	0.30
Eucalyptus	6	D	0.46
Fir, Balsam	1	K	0.24
Fir, Douglas	1	K	
Fir, Silver	1	K	0.46
Geronggang	4	E	
Guarea	6	E	0.34
Gum, American	5	C	0.34
Hackberry	5	F	0.37
Hemlock	1	L	0.26
Hickory	6	E	0.51
Hornbeam	5	E	0.41
Idigbo	4	J	0.30
Kroko	4	E	0.35
Jarrah	9	C	0.44
Jelutong	5	H	0.25
Kapur	7	E	0.39
Kauri (Agathis)	6	J	0.26
Kempas	7	E	0.49
Keruing	7	D	0.84
Koa	5	E	0.38
Larch	4	H	0.31
Lauan	5	E	
Lime	3	H	0.30
Mahogany	4	F	0.35
Makore	6	H	0.34
Mango	5	D	0.40
Mansonia	4	H	0.33
Maple, Hard	6	E	0.40
Maple, Soft	4	G	0.33

**Table I**  
(Continued)  
**Drying Group / Schedule**

<u>SPECIES</u>	<u>GROUP</u>	<u>SCHEDULE</u>	<u>lbs/cu ft FOR 1% MC</u>
Mengkulang	5	D	0.37
Meranti, Dk/Lt Red	5	F	0.28
Meranti, White	5	J	
Meranti, Yellow	7	J	0.32
Merawan	7	H	
Merbau	7	D	0.44
Mersawa	8	E	
Monkey Pod	5	A	0.36
Muhuhu	8	B	0.52
Minunga	7	J	0.30
Miangon	6	E	0.34
Nyatoh	6	E	0.49
Oak, American/English	9	C	0.41
Oak, Japanese	8	C	0.36
Obeche	1	L	0.21
Olive, E. Africa	7	E	0.51
Omu	7	A	0.35
Opepe	7	E	0.41
Paduak, African	4	J	0.40
Pecan	6	E	0.47
Persimmon	6	C	
Pine, Maritime	1	L	0.28
Pine, Parana	2	D	
Pine, Ponderosa	1	L	.028
Pine, Radiata	1	K	.026
Pine, Red	1	L	
Pine, Scots	2	F	0.28
Pine, E, White	1	L	
Poplar, Black	6	E	
Poplar, Yellow	3	K	0.25

**Table I**  
(Continued)  
**Drying Group / Schedule**

<u>SPECIES</u>	<u>GROUP</u>	<u>SCHEDULE</u>	<u>lbs/cu ft FOR 1% MC</u>
Purpleheart	6	e	0.48
Ramin (Melawis)	4	c	
Rhodesian Teak	8	d	0.50
Rosewood, Indian	6	e	0.47
Sapele	5	a	0.34
Sassafras	6	d	
Satinwood	5	c	0.49
Sepetir	7	g	0.37
Seraya, Red	5	f	
Spruce, Quropean	1	k	0.25
Spruce, Sitka	1	j	0.24
Sterculia, Brown	9	b	0.45
Sterculia, Yellow	8	c	0.43
Sycamore	6	a	0.33
Tamarack	1	k	
Teak	4	h	0.35
Utile (Sipo)	5	a	0.36
Walnut	5	e	0.35
Walnut / Claro	NOT RECOMMENDED		
Whitewood (Yellow Poplar)	3	k	0.25
Willow	3	d	0.20
Yew	4	g	0.37
Yellow Poplar	3	k	0.25

**IF you wish to dry a species which is not in this table, contact Ebac Incorporated for assistance.**

**TABLE II**

**Drying Schedules By Lumber Thickness And Moisture Content**

Average Lumber Moisture Content MC%	Maximum			7/4 to 12/4 (1 3/4 - 3°)			Over 12/4 (Over 3°)		
	Temperature °F	Temperature °C	Minimum RH%	Maximum Temperature °F	Maximum Temperature °C	Minimum RH%	Maximum Temperature °F	Maximum Temperature °C	Minimum RH%
<b>SCHEDULE A</b>									
Green - 60	95	35	70	95	35	75	95	35	80
60 - 40	95	35	60	95	35	65	95	35	70
40 - 30	104	40	50	95	35	55	95	35	60
30 - 20	113	45	40	104	40	45	104	40	50
20 - 15	122	50	35	122	50	40	113	45	45
15 - 10	140	60	30	140	60	35	131	55	40
Below 10	140	60	Min	140	60	30	140	60	30
<b>SCHEDULE B</b>									
Green - 40	104	40	85	104	40	90	95	35	90
40 - 30	104	40	80	104	40	85	95	35	90
30 - 25	113	45	75	104	40	80	104	40	85
25 - 20	122	50	70	113	45	75	104	40	80
20 - 15	131	55	60	122	50	65	122	50	70
15 - 10	140	60	50	131	55	55	122	50	60
10 - 8	140	60	40	140	60	45	131	55	50
Below- 8	140	60	30	140	60	30	140	60	35
<b>SCHEDULE C</b>									
Green - 60	104	40	85	104	60	90	95	35	90
60 - 40	104	40	80	104	60	85	95	35	90
40 - 35	113	45	75	104	60	80	104	40	85
35 - 30	113	45	70	104	55	75	104	40	80
30 - 25	113	45	65	113	50	70	104	40	75
25 - 20	122	50	60	122	45	65	113	45	70
20 - 15	140	60	50	131	40	55	122	50	60
15 - 10	140	60	40	140	40	45	131	55	50
10 - 8	140	60	30	140	40	35	140	60	40
Below 8	140	60	Min	140	40	30	140	60	35

**TABLE II**  
(Continued)  
**Drying Schedules by Lumber Thickness And Moisture Content**

Average Lumber Moisture Content MC%	Maximum Temperature			7/4 to 12/4 (1 3/4 - 3")			Over 12/4 (Over 3")		
	°F	°C	Minimum RH%	Maximum Temperature °F	°C	Minimum RH%	Maximum Temperature °F	°C	Minimum RH%

<u>SCHEDULE D</u>									
Green - 60	104	40	85	104	40	90	95	35	90
60 - 40	104	40	80	104	40	85	95	35	90
40 - 35	104	40	70	104	40	75	95	35	80
35 - 30	113	45	60	104	40	65	104	40	70
30 - 25	113	45	50	113	45	55	104	40	60
25 - 20	122	50	40	122	50	45	113	45	50
20 - 15	140	60	30	131	55	35	122	50	40
15 - 10	140	60	Min	140	60	30	131	55	35
Below 10	140	60	Min	140	60	Min	140	60	30

<u>SCHEDULE E</u>									
Green - 60	113	45	85	104	40	90	104	40	90
60 - 40	122	50	80	113	45	85	104	40	85
40 - 30	122	50	75	113	45	80	113	45	85
30 - 25	131	55	65	122	50	70	113	45	75
25 - 20	140	60	55	122	50	60	122	50	65
20 - 15	140	60	45	131	55	50	122	50	55
15 - 10	140	60	40	140	60	45	131	55	50
Below- 10	140	60	Min	140	60	30	140	60	35

<u>SCHEDULE F</u>									
Green - 60	113	45	75	104	40	80	104	40	85
60 - 40	122	50	70	113	45	75	104	40	80
40 - 30	122	50	60	113	45	65	113	45	70
30 - 25	131	55	50	122	50	55	113	45	60
25 - 20	140	60	45	122	50	50	122	50	55
20 - 15	140	60	40	131	55	45	122	50	50
15 - 10	140	60	40	140	60	45	131	55	50
Below 10	140	60	30	140	60	30	140	60	35

**TABLE II**  
(Continued)  
**Drying Schedules by Lumber Thickness and Moisture Content**

Average Lumber Moisture Content MC%	Maximum Temperature			7/4 to 12/4 (1 3/4 - 3")			Over 12/4 (Over 3")		
	°F	°C	Minimum RH%	Maximum Temperature °F	°C	Minimum RH%	Maximum Temperature °F	°C	Minimum RH%
<b>SCHEDULE G</b>									
Green - 60	113	45	85	104	40	90	104	40	90
60 - 40	122	50	80	113	45	85	113	45	90
40 - 30	122	55	80	122	50	85	113	45	90
30 - 25	122	55	75	131	55	80	122	50	85
25 - 20	131	60	70	131	55	75	131	55	80
20 - 15	131	60	55	131	55	60	131	55	65
15 - 10	140	60	40	140	30	45	131	55	50
Below 10	140	60	Min	140	30	30	140	60	35
<b>SCHEDULE H</b>									
Green - 50	122	50	80	122	50	85	113	45	90
50 - 40	131	55	75	131	55	80	122	50	85
40 - 30	140	60	65	131	55	70	131	55	75
30 - 20	140	60	55	131	55	60	131	55	65
20 - 10	140	60	40	140	60	45	131	55	50
Below - 10	140	60	Min	140	60	30	140	60	35
<b>SCHEDULE J</b>									
Green - 50	122	50	70	121	55	75	122	50	80
50 - 40	131	55	60	121	55	65	131	55	70
40 - 30	140	60	50	131	55	55	131	55	60
30 - 20	140	60	40	140	60	45	131	55	50
20 - 10	140	60	30	140	60	35	140	60	40
Below 10	140	60	Min	140	60	30	140	60	35

**TABLE II**  
(Continued)  
**Drying Schedules by Lumber Thickness and Moisture Content**

Average Lumber Moisture Content MC%	Maximum Temperature			7/4 to 12/4 (1 3/4 - 3")			Over 12/4 (Over 3")		
	°F	°C	Minimum RH%	Maximum Temperature °F	°C	Minimum RH%	Maximum Temperature °F	°C	Minimum RH%

<u>SCHEDULE A</u>									
Green - 50	122	50	80	122	50	85	113	45	90
50 - 30	131	55	70	131	55	75	122	50	80
30 - 20	140	60	60	131	55	65	131	55	70
20 - 15	140	60	40	140	60	45	131	55	50
15 - 10	140	60	30	140	60	35	140	60	40
Below 10	140	60	Min	140	60	Min	140	60	30

<u>SCHEDULE B</u>									
Green - 40	122	50	70	113	45	75	113	45	80
40 - 20	140	60	40	131	55	45	131	55	50
20 - 10	140	60	30	140	60	35	140	60	40
Below- 10	140	60	Min	140	60	Min	140	60	30

**NOTES:** The above schedules are intended as a guide. They may be altered within the operating range of the drying equipment according to experience gained during previous drying cycle. However, care should be exercised when altering schedules. If in doubt – **REDUCE THE TEMPERATURE.**

## Minimum Drying Times For MF Lumber Dryers:

Listed below are the estimated times in hours to dry through each lumber moisture content range. The minimum total drying time is found by adding together all the individual times in the column for the species being dried. (Find the drying group and schedule in Table I). Multiply this total by the appropriate thickness and schedule factors given below. Divide the result by 24 to find the total time in days. Allow time for heat up, such as 1 or 2 days. Different load sizes will vary the actual drying time.

### Estimated Time In Hours:

		Drying Groups									
Lumber Moisture Content		Range	1	2	3	4	5	6	7	8	9
	Each 10% above 40%		48	48	55	62	70	79	88	98	110
	40% - 35%		24	24	27	31	35	34	44	51	61
	35% - 30%		24	24	27	31	35	36	44	54	65
	30% - 25%		24	24	27	31	35	45	55	67	81
	25% - 20%		24	24	27	32	43	56	69	84	102
	20% - 15%		24	24	29	40	54	70	86	104	126
	15% - 10%		24	26	35	49	69	88	110	125	154
	10% - 8%		10	15	20	28	39	50	62	72	87
	8% - 6%		13	18	24	34	48	61	76	88	106

Lumber Thickness	Up To	4/4	5/4	6/4	7/4	8/4	9/4	10/4	11/4	12/4	13/4	14/4	15/4	16/4
------------------	-------	-----	-----	-----	-----	-----	-----	------	------	------	------	------	------	------

Thickness Factor	0.6	0.8	1.0	1.2	1.4	1.65	1.9	2.15	2.4	2.6	2.9	3.1	3.4
------------------	-----	-----	-----	-----	-----	------	-----	------	-----	-----	-----	-----	-----

Schedule	A - B - C - D	E - F - G - H - J	K - L
----------	---------------	-------------------	-------

Schedule Factor	1.0	1.5	2.0
-----------------	-----	-----	-----

## Average Load Sizes For Each MF2:

	<u>SOFTWOODS</u>	<u>HARDWOODS</u>
1"	2,000 - 3,500 BF	3,000 - 5,000 BF
2"	3,000 - 5,000 BF	6,000 - 8,000 BF
3"	5,000 - 7,000 BF	8,000 - 10,000 BF

If quantities needed are larger than those listed above, additional machines can be connected together in the appropriate size kiln.

**Note:** The schedules are purposely conservative. As you become experienced with your kiln, you can increase the load size to be dried.

# APPENDIXES

## APPENDIX I

### Oven Dry Method For Determining Average Moisture Content:

Although moisture meters come in handy, the best method of determining moisture content is the oven dry method which should be done every time you make an adjustment.

The oven dry method is actually more accurate than moisture meters, but not very convenient. You do need an accurate scale for weighing the wood samples and an oven (a baking oven will do) to bake the sample.

Select a plank from the wood to be dried and cut 6 inches from each end and discard these cutoffs. (They will be much drier than the rest of the piece). Cut several one-inch pieces from one end until you have about a pound of weight. Weigh these and record the wet weight. Weigh the remaining portion of the plank and add it to the middle of the lumber stack in the kiln where it can be retrieved periodically to monitor equilibrium.

Place the 1" sample in a 225°F oven for 24 to 36 hours, then weigh again. This is the oven dry weight. Use the formula below to calculate the starting MC of the sample.

$$MC = \frac{\text{Wet Weight} - \text{Dry Weight}}{\text{Dry Weight}} \times 100\%$$

The moisture content of the lumber in the stack can now easily be monitored by periodically pulling the sample plank from the stack and weighing it. First, however, calculate the future dry weight of the plank by using the MC just calculated.

$$\text{Plank Dry Weight} = \frac{\text{Wet Weight}}{1 + \frac{MC}{100}}$$

Now having calculated the plank dry weight, use the formula above for determining MC to monitor drying progress.

**Example:** You have weighed your 1” samples and they weigh 1.35 lbs. The remaining plank weighs 15.4 lbs and is added to the lumber stack in the kiln and the dryer can be turned on. After drying the samples 36 hours in an oven, you weigh them and the weight is 0.94 lb.

$$\text{Starting MC} = \frac{1.35 \text{ lb} - 0.94 \text{ lb}}{0.94 \text{ lb}} \times 100 = 44\%$$

Now calculate the future dry weight of the plank in the kiln:

$$\text{Plank Dry Weight} = \frac{15.4}{1 + \frac{44}{100}} = 10.7 \text{ lb}$$

After a few weeks of drying, the plank is removed from the stack and weighs 12.2 lb,

$$\text{Starting MC} = \frac{12.2 \text{ lb} - 10.7 \text{ lb}}{10.7 \text{ lb}} \times 100 = 14\%$$

## APPENDIX II

### WOOD DEGRADE

#### **Possible Faults During Lumber Drying:**

Wood shrinkage is responsible for nearly all forms of drying degrade. Correct drying techniques, particularly with regard to drying schedules, minimizes this sort of fault, though it is impossible to eliminate it entirely. The following are some of the commoner forms of degrade.

#### **Splitting and Checking:**

If the rate of surface evaporation is far in excess of the moisture transfusion rate from the center, then too steep a moisture gradient is induced in the wood. The exterior tends to shrink greatly onto the center, resulting in sever stresses – sometimes sufficient to tear the outer fibers apart. This condition is known as checking.

Checking mainly occurs along the rays on the edges of quarter sawn material and on the faces of tangentially cut boards. This is because shrinkage along the growth rings is greater than that at right angles to them.

Lumber is more prone to checking in the early stages of drying; the moisture gradient inevitable flattens out as moisture departs. Further, it is the ends which are most prone, as vapor moves more easily longitudinally and out of the ends, thus drying these faster. So zones near the end of the board have a tendency to dry and shrink in advance of the remainder, causing end splits which may extend a marked distance along the board. The answer to these problems is to keep moisture evaporation at a reasonable level, particularly in the early stages of drying, as provided in the schedules. However, the type and quality of the lumber and any previous treatment it has had will affect its tendency to split. It is not always possible to prevent end splitting, even by raising the RH higher than recommended, and planks are generally cut somewhat longer than required in order to compensate.

Such wastage is uneconomical in the drying of expensive, high quality stock, such as oak furniture squares, and it is common practice to control rapid drying and consequent splitting on the ends of these by sealing them with a moistly resistant paint or wax. But, despite undoubted reduction of checking and end splitting this procedure is not always economical.

End cleats, useful in air drying, should be removed from lumber in the kiln since, by restraining proper shrinkage, they may encourage splitting.

Splits may already be present in wood which has been partially dried in the air before transference to the kiln. Furthermore, they may have closed up so as to be invisible. Kiln drying will expose these faults, no matter how carefully it is carried out, and the best that one can hope for is to prevent these faults from extending further. Even this may prove difficult.

It should be noted that surface checks will tend to close when the lumber has dried to uniform moisture content, though not in severe cases.

### **Honeycombing:**

This is, essentially internal splitting. Case splitting is not an inevitable result of the strain on the stretched outer zone, since wood has certain elasticity. Should the strain of expansion not demand a yield greater than the wood's elasticity, there will be no damage. But if the elastic limit is exceeded a state of "permanent set" will develop. The outer zone sets in expansion, the inner zone likewise in compression. As drying continues, the inner zone begins to shrink in excess of the resisting expanded outer zones. The roles in case splitting are reversed, with the center under tension and the surface in compression. Stresses develop, which, if large enough, will tear apart the stretched fibers of the center and cause the condition of honeycombing.

Honeycombing may not be externally visible, apart from slight caving in on the tangential faces.

Care in the early stages of drying should prevent honeycombing, and exposing the wood to high humidity's, as with case-hardening, will normally prevent the development of heavy stressing.

Deep surface checking may be mistaken for honeycombing, particularly when the surface ends of the splits have closed up during the final stages of drying, leaving internal checks to be discovered on cross-cutting.

### **Distortion:**

This is caused by differential drying by differential drying in lumber containing distorted or curved grain.

Shrinkage along the grain is normally negligible for practical purposes, but certain woods shrink along the grain by as much as 1 or 2 percent, often

resulting in appreciable longitudinal distortion. Poor quality woods, and woods in which the grain is seldom straight, such as elm, are extremely prone to distortion, and these must be piled carefully with sticks at short intervals or even weighted down. The overall improvement in shape should compensate for any increase in splitting.

Low temperature drying schedules (Group 1, Lumber Drying Schedules) are recommended for woods particularly prone to distortion, since high temperatures increase the plasticity of wood as well as increasing shrinkage, and the increased plasticity of the wood makes the effect of the increased shrinkage double bad in terms of distortion.

### **Case-Hardening:**

This result from the stresses produced when the exterior of the wood has set in expansion and is finally under compression, while the interior is in Tension. These permanent sets develop as in honeycombing, by the woods elastic limit being exceeded.

To determine the presence and gravity of case-hardening stresses, cut off cross-sections about 12 mm thick, at least 200 mm in from the end of the test plank, and cut out the center portions to within about 25 mm of one end.

The immediate behavior of these prongs (i.e. - whether they bend outwards or inwards) indicates the stresses present in the wood at the time of cutting, but their behavior after drying for 24 hours in room conditions indicates whether these stresses are permanent and serious. Prongs cut from a plank in the early stages of drying will at first point outward, later straightening up if no permanent set has developed, or curving inwards to indicate that one has.

As drying the plank proceeds, the inner portions dry and try to shrink by the normal amount, while being resisted (in case-hardening) by the outer shell. Thus there is a gradual changeover of stress distribution. Test prongs cut from wood in this condition will immediately curve inwards and the curvature will increase if the inside was wetter than the outside when cut.

Prongs cut from heavily case-hardened wood will press tightly together after drying. If case hardening is slight, the prongs may be straight on cutting and become slightly curved later.

### **Collapse:**

Too rapid departure of the free moisture from cells, occasioned by high temperatures, can lead the cells to collapse. Certain species of Eucalyptus

are very prone to collapse, even at moderate temperatures. Collapse manifests itself as local shrinkage which, if great, may in its turn lead to severe honeycombing.

Collapse may often be removed by high temperature steam treatment when the wood is nearly dry, but this is beyond the scope of the handbook.

Figure 14  
WOOD DAMAGE PICTURE

## APPENDIX III

### **Troubleshooting:**

In case of trouble, first check that all instructions in the manual have been carefully followed. Next, go through the following chart. If the problem is still not resolved, call Ebac Incorporated. In most cases, a simple phone call will resolve the question.

### **System Overview:**

Air is drawn into the dryer where the moisture is extracted from it. Moisture is extracted when the air is passed through the evaporator coil. This coil is cooled to a temperature lower than the dew point temperature of the air and hence condensation forms on it. The dryer consists of 7 parts:

1. Fan motor to draw the air through the unit.
2. Compressor which drives the refrigeration circuit.
3. Evaporator coil – cold section of the refrigeration circuit.
4. Condenser coil – hot section of the refrigeration circuit.
5. Capillary tube – separates the hot and cold section of the refrigeration circuit with regard to gas flow.
6. Filter dryer – removes any contaminants flowing around the refrigeration circuit.
7. Auxiliary heater.

# MF Dryer

## Symptoms

Unit completely Inoperative

The machine has shut off during mid run. No lights are lit on the control panel.

The machine has shut off during mid run. The off light on the control panel is lit.

Normal operation but low water extraction.

## Possible Fault

1. No power supply. Check the breaker and the power connection.

1. Overheat protector. Allow the machine to cool. When the off light has relit, restart the machine.

1. Overheat protector. The protector has already cooled. Restart the machine.

2. Over current protector. Electrical line voltage is too high or the fan motor has burned out. Restart the machine.

1. Dry lumber. As the moisture content falls below 10%, you may notice a drop in the water extraction. Monitor the moisture content daily to avoid over drying.

2. Compressor overheating. If kiln temperature is over rating for unit, thermal circuit breaker in compressor in compressor may be opening. Check to make sure vent is operational.

3. Refrigerant gas loss from circuit. Compare by touch the temperature of the top and bottom refrigeration coil. Bottom coil should be noticeably cooler than the top when the drying on light is lit.

4. Blocked or frozen drain hose. Water may be flooding kiln.

## MCU1002 Control Unit

### Symptoms

Green fan start switch does not illuminate when pressed

### Possible Fault

1. Main power isolator “OFF”. Switch to “ON”
2. Overload adjacent to the contactor C3 tripped.
  - Ensure fans in the top of the appropriate drying unit will rotate freely and that the motors are in serviceable condition.
  - Ensure that all three phases are available from the main supply to the control system to the fans inside the appropriate drying system. (see item 5 in the MCU1100 operation)
  - Ensure the overload setting is correct. Adjust by sliding in indicator pointer to the correct value. After correcting fault press the square RED reset button on the overload.
3. Circuit breaker “3” positioned on the rear of the module tripped, indicated by a line of three “0” signs on the switch. Check interconnecting wiring between control unit and drying unit for damage or short circuiting. After correcting fault, select the position which indicates three “I” signs.

Red stop switch is illuminated

1. Power supply has been temporarily interrupted and then restored. Press green start button.
2. Overheat detectors in appropriate drying unit have detected an excessive temperature. Ensure fans in the appropriate drying unit will rotate freely and that the motors are in serviceable condition then press green start button.

## MCU1002 Control Unit (Continued)

Red stop switch is illuminated  
(continued)

3. Internal fan overload adjacent to contact C3 has tripped.

- Ensure fans in the top of the appropriate drying unit will rotate freely and that the motors are in serviceable condition. Press the square, red reset button on the overload adjacent to contactor C3. Press green restart button.
- Ensure the overload setting is correct. Adjust by sliding indicator pointer to the correct value. Press the square red reset button on the overload. C3 press green start button.

“Drying” phase indicator lamps will not illuminate when drying is called for and the appropriate drying unit fails to produce water.

1. Circuit breaker “1” position on the rear of the module has tripped, indicated by a line of “O” signs on the switch.

- Ensure that all 3 phases are available from the main supply to the control system and from the control system to the refrigerant compressor. After correcting fault, select the position which indicates three “I” signs.
- Check interconnecting wiring between control unit and drying unit for damage or short-circuiting.
- Ensure supply voltage is correct. Low voltage may damage the drying equipment.

“Heating” phase indicator lamps will not illuminate when drying is called for and the appropriate drying unit’s heater bank fails to operate.

1. Circuit breaker “2” positioned on the rear of the module has tripped indicated by a line of “O” signs on the switch. Check interconnecting wiring between control unit and drying unit for damage or short circuiting. After correcting fault select the position which indicates three “I” signs.

**MCU1002 Control Unit  
(Continued)**

“Cooling” phase indicator lamps  
will not illuminate

1. Cooling circuit overload adjacent to contactor C4 has tripped.
  - Ensure fans and louver motor units in the appropriate cooling units operate freely and are in serviceable condition. Press square, red reset button.
  - Ensure overload is set to the correct value. If necessary, adjust overload by sliding indicator pointer to the correct value. Press the square, red reset button on the overload.

## MCU1100 Control Unit

Green start switch does not remain illuminated when pressed.

1. Main power isolator “OFF”. Switch to “ON”
2. Overload adjacent to the contactor C3 tripped.
  - Ensure fans in the top of the appropriate drying unit will rotate freely, and that the motors are in serviceable condition.
  - Ensure that all three phases are available from the main supply to the control system to the fans inside the appropriate drying system. (See item 5 in the MCU1100 operation section).
  - Ensure the overload setting is correct. Adjust by sliding in indicator pointer to the correct value. After correcting fault press the square RED reset button on the overload.
3. Circuit Breaker “3” positioned on the rear of the module tripped, indicated by a line of three “O” signs on the switch. Check interconnecting wiring between control unit and drying unit for damage or short circuiting. After correcting fault, select the position which indicates three “I” signs.

Red stop switch is illuminated

1. Power supply has been temporarily interrupted and then restored. Press green start button.
2. Overheat detectors in appropriate drying unit have detected an excessive temperature. Ensure fans in the appropriate drying unit will rotate freely and that the motors are in serviceable condition then press green start button.
3. Internal fan overload adjacent to contact C3 has tripped.
  - Ensure fans in the top of the appropriate drying unit will rotate freely and that the motors are in serviceable condition. Press the square, red reset button on the overload adjacent to contactor C3. Press green start button.

## MCU1100 Control Unit (Continued)

Red stop switch is illuminated  
(continued)

- Ensure the overload setting is correct. Adjust by sliding in indicator pointer to the correct value. After correcting fault press the square RED reset button on the overload. C3 Press GREEN start button.

“Drying” indicator lamp will not illuminate when drying is called for and the appropriate drying unit fails to produce water.

1. Circuit breaker “1” positioned on the rear of the module has tripped, indicated by a line of “O” signs on the switch.
  - Refrigeration unit failed, contact Ebac for support.
  - Ensure that all 3 phases are available from the main supply to the control system and from the control system to the refrigerant compressor inside the appropriate drying system (see item 5 in the MCU1100 operation section). After correcting fault, select the position which indicates three “I” signs.
  - Check interconnecting wiring between control unit and drying unit for damage or short-circuiting.
  - Ensure supply voltage is correct. Low voltages may damage the drying equipment.

## MCU1100 Control Unit (Continued)

“Heating” phase indicator lamps will not illuminate when drying is called for and the appropriate drying unit’s heater bank fails to operate.

1. Circuit breaker “2” positioned on the rear of the module has tripped indicated by a line of “O” sings on the switch. Check interconnecting wiring between control unit and drying unit for damage or short circuiting. After correcting fault, select the position which indicates three “I” signs.

“Cooling phase indicator lamps will not illuminate when cooling is called for.

1. Cooling circuit overload adjacent to contactor C4 has tripped.
  - Ensure fans and louver motor units in the appropriate cooling units operate freely and are in serviceable condition. Press square RED reset button.
  - Ensure overload is set to the correct value of 9A. If necessary, adjust overload by sliding indicator pointer to the correct value. Press the square, red reset button on the overload.

## APPENDIX IV

### SPECIFICATIONS - MF2

Height	48"
Width	44"
Depth	18 ½"
Weight	281 Lbs
Airflow	1750 CFM
Power Rating (Dryer)	3.5 KW (Maximum)
Power Rating (Heater)	4.5 W (Operates Intermittently)
Power Supply	220V / 60 Hz / 1 Phase 30 Amps 220V / 60 Hz / 3 Phase 30 Amps
Maximum Operating Temp	140°F (60°C)
Finish	Epoxy / Vinyl Coated Steel
Refrigerant Type:	R-22
Refrigerant Charge:	2.7 KG / 95 ounces

#### Special Features:

- Stainless Steel Drain Tray for corrosion resistance.
- Slim shape takes up little space inside the drying chamber.
- Expandable to meet your growing needs.

**Spare Parts List - MF2:**

	Description	Ebac Part No.	QTY	
1	Drain Tray	2035830	1	
2	Evaporator Coil with Cap Tube & Filter Dryer	1330902	1	
3	Condenser Coil	3020725	1	
4	Compressor	220V / 60Hz / 1 PH	3944901	1
		220V / 60Hz / 3 PH	3944902	1
5	Filter Dryer	3020904	1	
6	Fan Blade	3040119	1	
7	Fan Motor	3030140	1	
8	Heaters	3031607	3	
9	Compressor Start Capacitor	3830906 N/A	1	
10	Compressor Run Capacitor	3830205 N/A	1	
11	Relay	3830204 N/A	1	
12	Fan Run Capacitor	3030927	1	
13	Capillary Tubing	3014251	184 inches	
	0.047" Length 46" x 4			

**NOTE: Numbers coincide with components layout.**

APPENDIX V  
DRAWINGS & WIRING DIAGRAMS